

Lag 1	Skive 3	Bjørn Berven-Hanssen		
Grovpistol Press		Sola PK	V55	
25.06.2019		NM bane 2019	NM Pistol 2019	
Press 1 serie				
		23.5s	8.3	↑
		53.2s	10.4	↓
		1:28m	10.1	←
		2:37m	10.1	↓
		3:57m	9.5	↓
		22.5s	9.4	←
		1:06m	10.4x	→
		1:42m	10.3	↓
		2:26m	9.3	↓
		3:18m	8.6	↗
		Serie	93 (1x)	
		Total	93 (1x)	
Press 2 serie				
		21.7s	9.9	↓
		1:25m	8.9	→
		1:49m	8.0	↗
		2:25m	10.0	↑
		3:00m	9.6	↓
		24.6s	10.4x	→
		51.2s	10.6x	←
		2:04m	9.6	↗
		2:35m	10.8x	↓
		3:42m	10.4x	↓
		Serie	93 (4x)	
		Total	186 (5x)	
Press 3 serie				
		21.9s	10.1	←
		51.5s	9.9	↘
		1:31m	10.3	↓
		2:48m	9.4	↓
		3:37m	8.8	→
		16.5s	10.0	↗
		43.3s	10.2	↗
		1:17m	9.0	↗
		2:10m	9.0	↓
		2:43m	9.7	↖
		Serie	93 (0x)	
		Total	279 (5x)	

Press 1 serie 	<table style="width:100%; border-collapse: collapse;"> <tr><td style="width:15%;">10.2s</td><td style="width:15%;">8.2</td><td style="width:15%; text-align: right;">↑</td></tr> <tr><td>38.4s</td><td>9.2</td><td style="text-align: right;">↖</td></tr> <tr><td>1:33m</td><td>7.8</td><td style="text-align: right;">↑</td></tr> <tr><td>1:58m</td><td>9.3</td><td style="text-align: right;">↘</td></tr> <tr><td>2:52m</td><td>9.2</td><td style="text-align: right;">→</td></tr> <tr><td>11.2s</td><td>9.2</td><td style="text-align: right;">↖</td></tr> <tr><td>47.1s</td><td>5.5</td><td style="text-align: right;">↗</td></tr> <tr><td>1:13m</td><td>10.8x</td><td style="text-align: right;">→</td></tr> <tr><td>1:49m</td><td>9.4</td><td style="text-align: right;">↗</td></tr> <tr><td>2:27m</td><td>9.7</td><td style="text-align: right;">↘</td></tr> <tr><td colspan="2">Serie</td><td style="text-align: right;">84 (1x)</td></tr> <tr><td colspan="2">Total</td><td style="text-align: right;">84 (1x)</td></tr> </table>	10.2s	8.2	↑	38.4s	9.2	↖	1:33m	7.8	↑	1:58m	9.3	↘	2:52m	9.2	→	11.2s	9.2	↖	47.1s	5.5	↗	1:13m	10.8x	→	1:49m	9.4	↗	2:27m	9.7	↘	Serie		84 (1x)	Total		84 (1x)
10.2s	8.2	↑																																			
38.4s	9.2	↖																																			
1:33m	7.8	↑																																			
1:58m	9.3	↘																																			
2:52m	9.2	→																																			
11.2s	9.2	↖																																			
47.1s	5.5	↗																																			
1:13m	10.8x	→																																			
1:49m	9.4	↗																																			
2:27m	9.7	↘																																			
Serie		84 (1x)																																			
Total		84 (1x)																																			
Press 2 serie 	<table style="width:100%; border-collapse: collapse;"> <tr><td style="width:15%;">10.1s</td><td style="width:15%;">9.4</td><td style="width:15%; text-align: right;">↘</td></tr> <tr><td>1:32m</td><td>7.2</td><td style="text-align: right;">→</td></tr> <tr><td>2:00m</td><td>8.5</td><td style="text-align: right;">↖</td></tr> <tr><td>2:47m</td><td>9.2</td><td style="text-align: right;">→</td></tr> <tr><td>3:05m</td><td>8.1</td><td style="text-align: right;">↗</td></tr> <tr><td>11.0s</td><td>9.6</td><td style="text-align: right;">↑</td></tr> <tr><td>1:01m</td><td>10.5x</td><td style="text-align: right;">↑</td></tr> <tr><td>1:48m</td><td>9.5</td><td style="text-align: right;">↘</td></tr> <tr><td>2:11m</td><td>8.8</td><td style="text-align: right;">→</td></tr> <tr><td>3:02m</td><td>8.4</td><td style="text-align: right;">↖</td></tr> <tr><td colspan="2">Serie</td><td style="text-align: right;">85 (1x)</td></tr> <tr><td colspan="2">Total</td><td style="text-align: right;">169 (2x)</td></tr> </table>	10.1s	9.4	↘	1:32m	7.2	→	2:00m	8.5	↖	2:47m	9.2	→	3:05m	8.1	↗	11.0s	9.6	↑	1:01m	10.5x	↑	1:48m	9.5	↘	2:11m	8.8	→	3:02m	8.4	↖	Serie		85 (1x)	Total		169 (2x)
10.1s	9.4	↘																																			
1:32m	7.2	→																																			
2:00m	8.5	↖																																			
2:47m	9.2	→																																			
3:05m	8.1	↗																																			
11.0s	9.6	↑																																			
1:01m	10.5x	↑																																			
1:48m	9.5	↘																																			
2:11m	8.8	→																																			
3:02m	8.4	↖																																			
Serie		85 (1x)																																			
Total		169 (2x)																																			
Press 3 serie 	<table style="width:100%; border-collapse: collapse;"> <tr><td style="width:15%;">10.0s</td><td style="width:15%;">10.4x</td><td style="width:15%; text-align: right;">→</td></tr> <tr><td>38.3s</td><td>8.6</td><td style="text-align: right;">↘</td></tr> <tr><td>1:58m</td><td>8.9</td><td style="text-align: right;">↖</td></tr> <tr><td>2:21m</td><td>8.5</td><td style="text-align: right;">→</td></tr> <tr><td>3:08m</td><td>7.7</td><td style="text-align: right;">↘</td></tr> <tr><td>9.75s</td><td>10.1</td><td style="text-align: right;">↖</td></tr> <tr><td>56.3s</td><td>8.1</td><td style="text-align: right;">↖</td></tr> <tr><td>1:19m</td><td>9.4</td><td style="text-align: right;">↖</td></tr> <tr><td>1:47m</td><td>10.0</td><td style="text-align: right;">↗</td></tr> <tr><td>2:36m</td><td>8.5</td><td style="text-align: right;">↘</td></tr> <tr><td colspan="2">Serie</td><td style="text-align: right;">86 (1x)</td></tr> <tr><td colspan="2">Total</td><td style="text-align: right;">255 (3x)</td></tr> </table>	10.0s	10.4x	→	38.3s	8.6	↘	1:58m	8.9	↖	2:21m	8.5	→	3:08m	7.7	↘	9.75s	10.1	↖	56.3s	8.1	↖	1:19m	9.4	↖	1:47m	10.0	↗	2:36m	8.5	↘	Serie		86 (1x)	Total		255 (3x)
10.0s	10.4x	→																																			
38.3s	8.6	↘																																			
1:58m	8.9	↖																																			
2:21m	8.5	→																																			
3:08m	7.7	↘																																			
9.75s	10.1	↖																																			
56.3s	8.1	↖																																			
1:19m	9.4	↖																																			
1:47m	10.0	↗																																			
2:36m	8.5	↘																																			
Serie		86 (1x)																																			
Total		255 (3x)																																			

Lag	Skive	Rune Finstad		
1	5	Grovpistol Press	Oslo Komm.Tj.M. Skl	V55
25.06.2019	NM bane 2019	NM Pistol 2019		
Press 1 serie		8.85s	8.3	←
		36.2s	8.8	←
		1:02m	10.3	←
		2:02m	10.2	←
		2:31m	8.0	↓
		15.1s	10.4x	←
		43.9s	10.0	↓
		1:21m	8.5	↑
		1:49m	9.7	↓
		2:34m	10.3	→
		Serie	91 (1x)	
		Total	91 (1x)	
Press 2 serie		13.9s	8.3	←
		43.3s	7.8	↓
		1:10m	10.3	↓
		1:44m	10.1	↓
		2:21m	9.0	↑
		12.8s	9.0	←
		1:17m	8.8	↓
		1:45m	9.1	←
		2:48m	10.7x	↓
		3:17m	9.8	↓
		Serie	89 (1x)	
		Total	180 (2x)	
Press 3 serie		13.0s	9.7	←
		1:29m	8.5	←
		1:54m	9.0	↖
		2:21m	10.5x	←
		2:58m	10.1	↙
		7.52s	4.1	↑
		1:10m	10.4x	→
		2:10m	9.7	↙
		2:46m	9.8	←
		3:17m	10.2	→
		Serie	88 (2x)	
		Total	268 (4x)	

Lag 1	Skive 6	Rune Hammer		
Grovpistol Press		Aron Skytterklubb Drammen		V55
25.06.2019		NM bane 2019		NM Pistol 2019
Press 1 serie 	12.8s	10.4x	←	
	42.8s	9.0	↑	
	1:20m	9.5	←	
	1:55m	9.4	→	
	2:29m	10.4x	↑	
	14.5s	10.4	↓	
	43.9s	10.0	↓	
	1:20m	10.0	↗	
	1:53m	10.2	↓	
	2:59m	8.6	↓	
Serie		95 (2x)		
Total		95 (2x)		
Press 2 serie 	13.6s	10.6x	↗	
	37.2s	10.4x	↓	
	1:06m	9.7	↓	
	1:37m	10.5x	→	
	2:54m	9.4	↓	
	13.5s	9.3	↓	
	43.1s	8.3	↗	
	1:35m	10.0	←	
	2:09m	10.4x	↑	
	2:42m	9.9	↓	
Serie		94 (4x)		
Total		189 (6x)		
Press 3 serie 	47.5s	10.4	↗	
	1:11m	10.0	↓	
	1:40m	10.3	→	
	2:13m	9.1	↓	
	2:48m	10.5x	↗	
	18.2s	10.5x	↓	
	47.7s	10.7x	←	
	1:42m	9.9	←	
	2:44m	9.4	↓	
	3:18m	9.8	↗	
Serie		96 (3x)		
Total		285 (9x)		

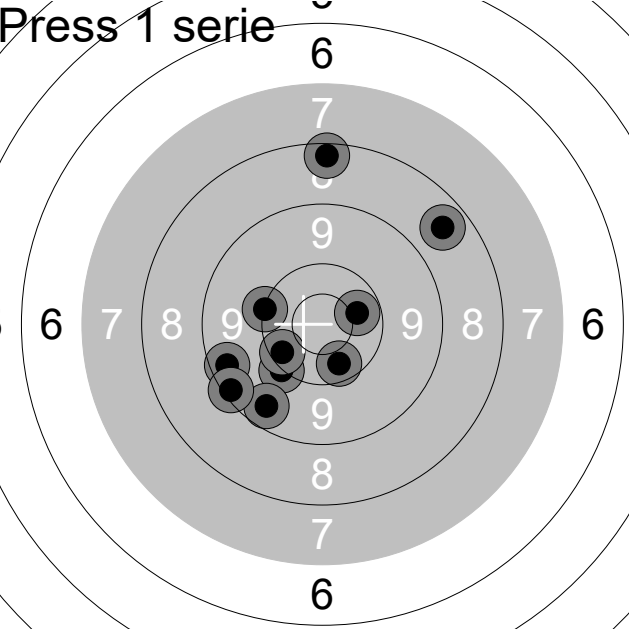
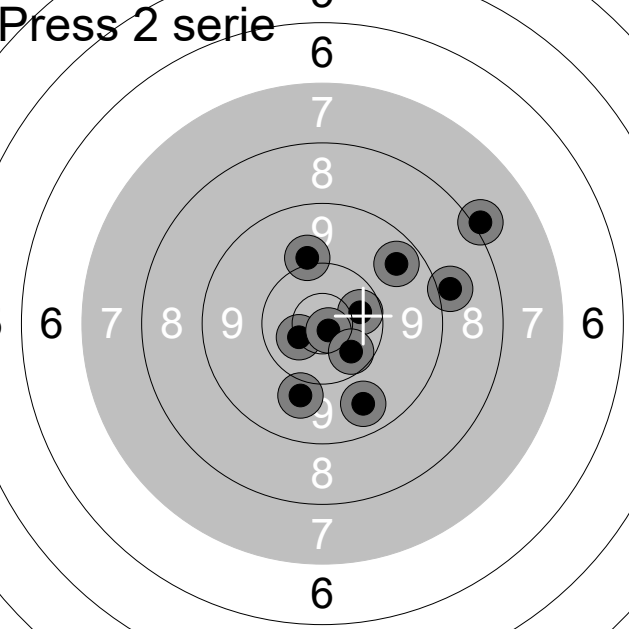
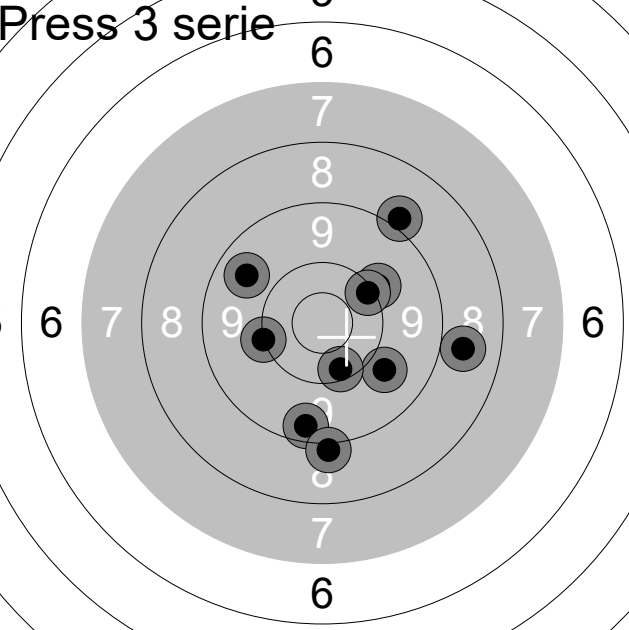
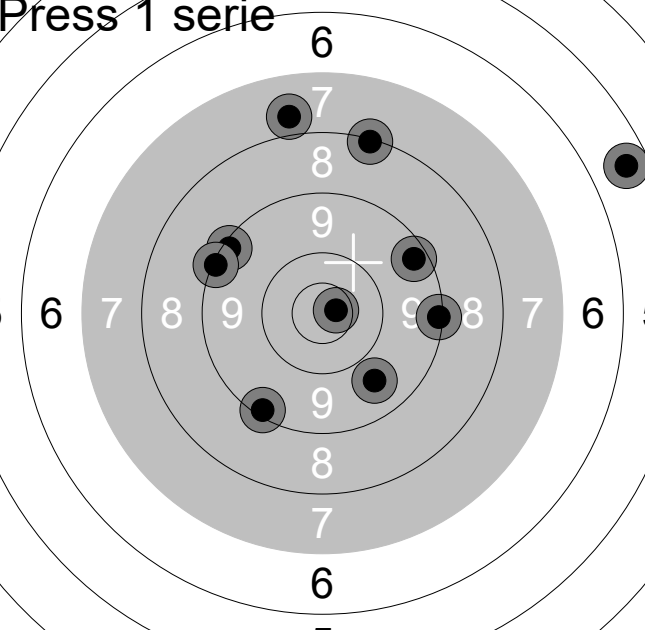
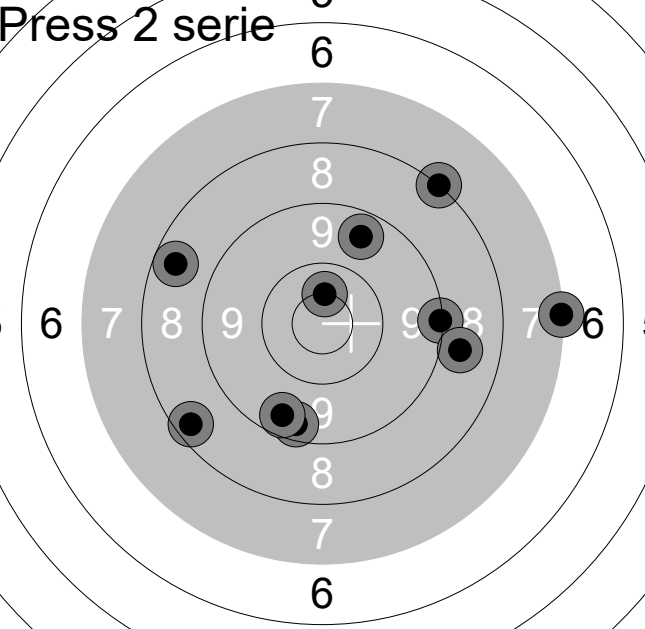
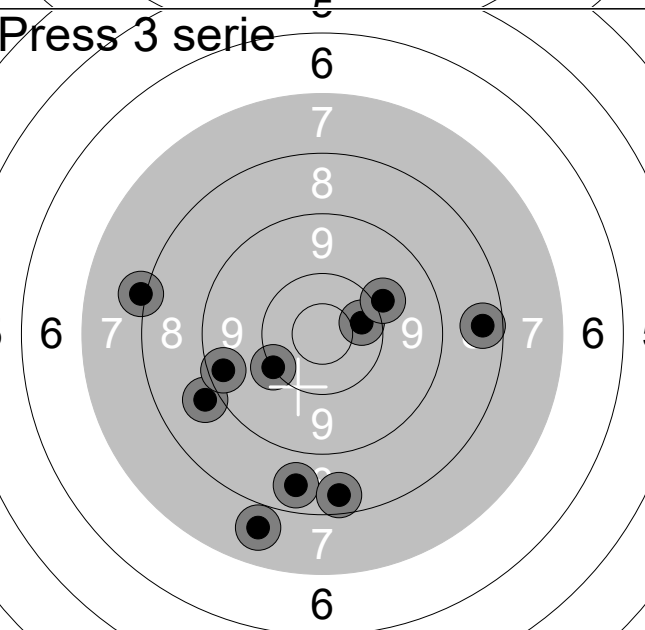
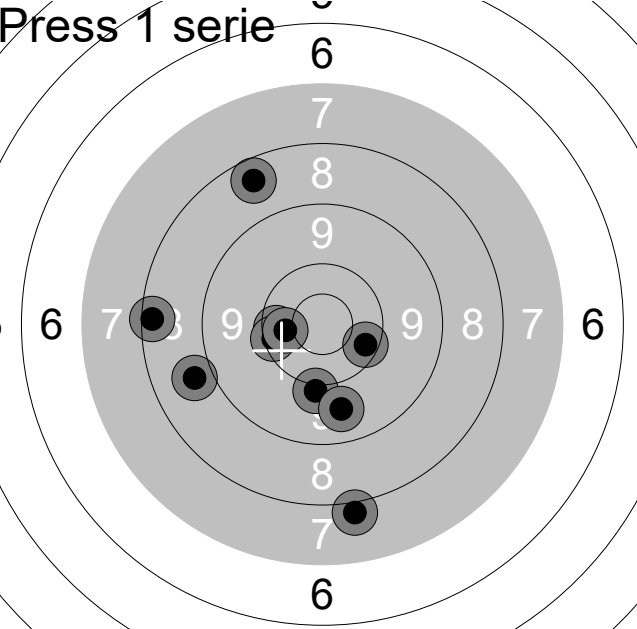
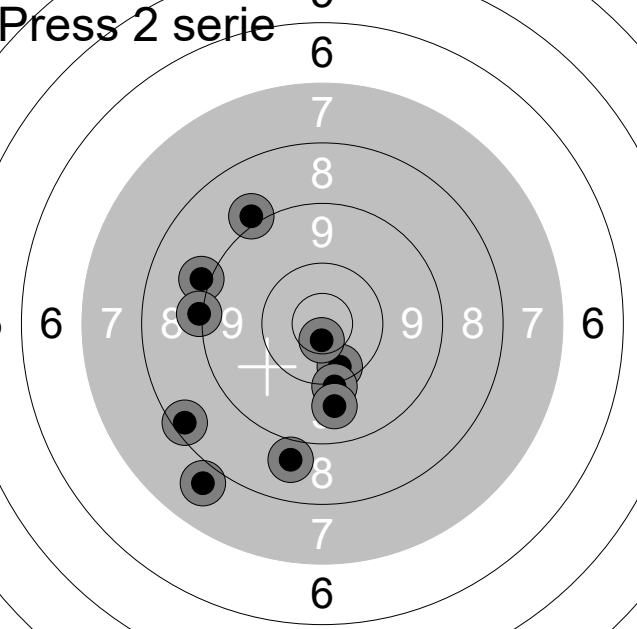
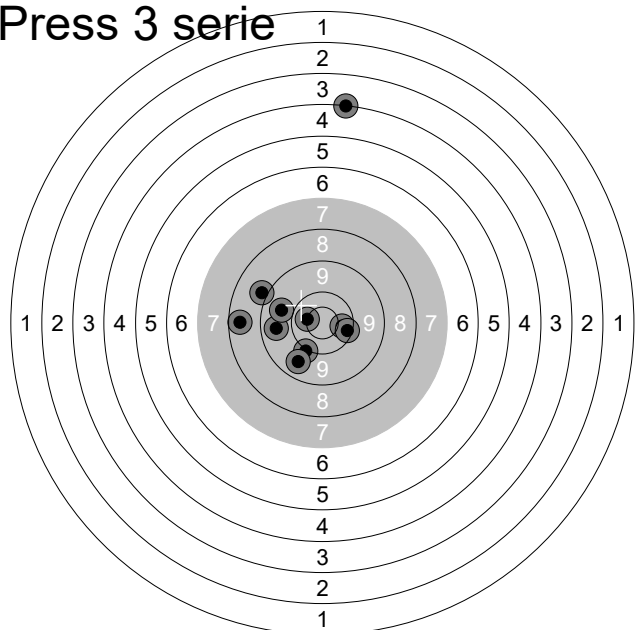
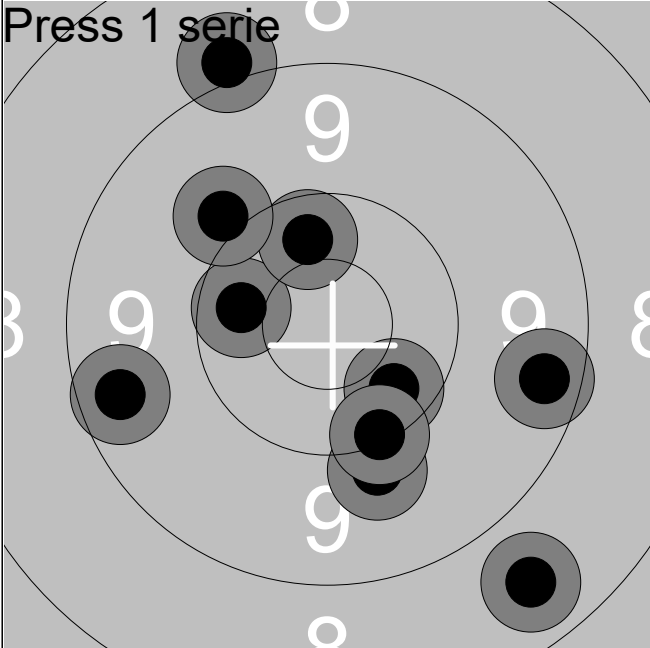
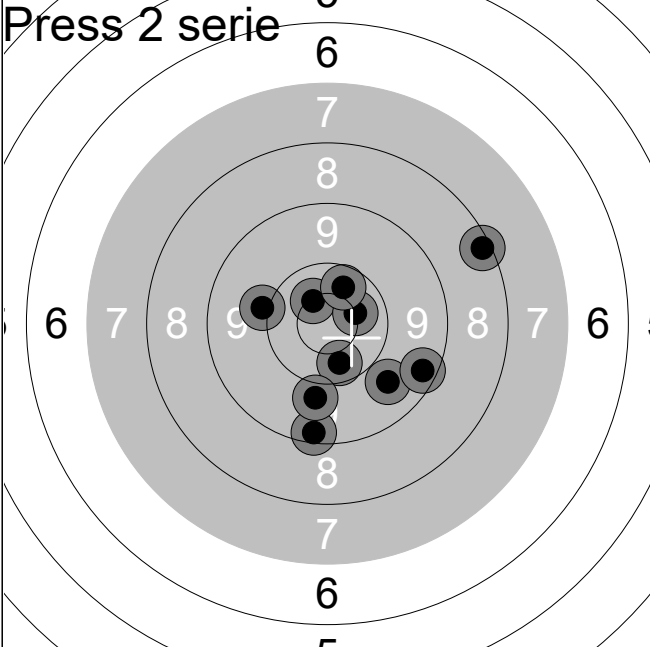
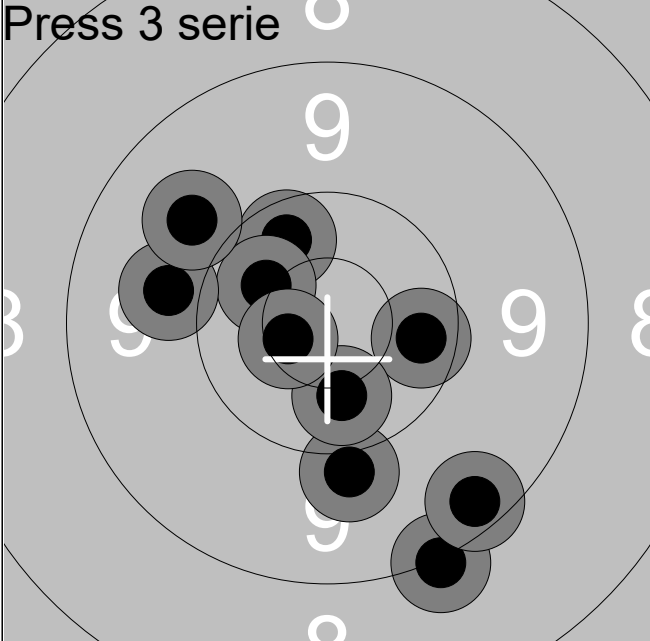
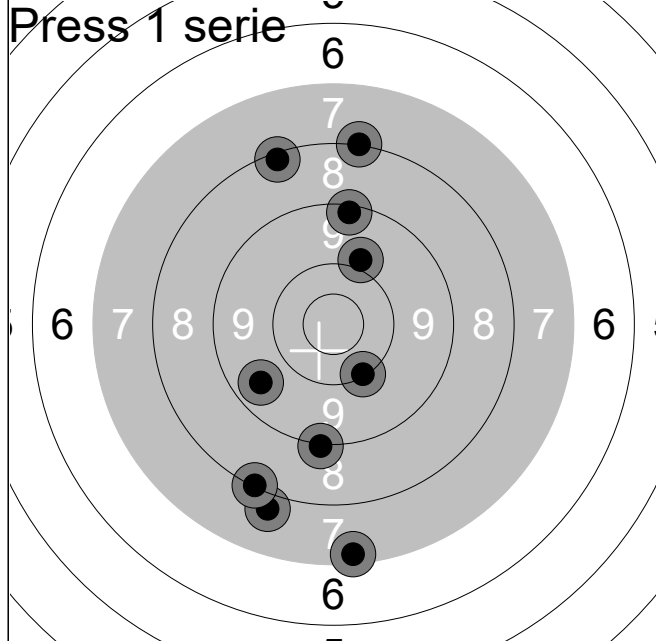

14.9s	8.3	↑
42.3s	7.9	↓
1:10m	10.1	↓
1:46m	9.1	↓
2:41m	8.1	↑
14.6s	9.3	↑
1:07m	10.0	↑
2:13m	7.3	↓
2:45m	9.6	↙
3:21m	8.2	↓
Serie	85 (0x)	
Total	85 (0x)	

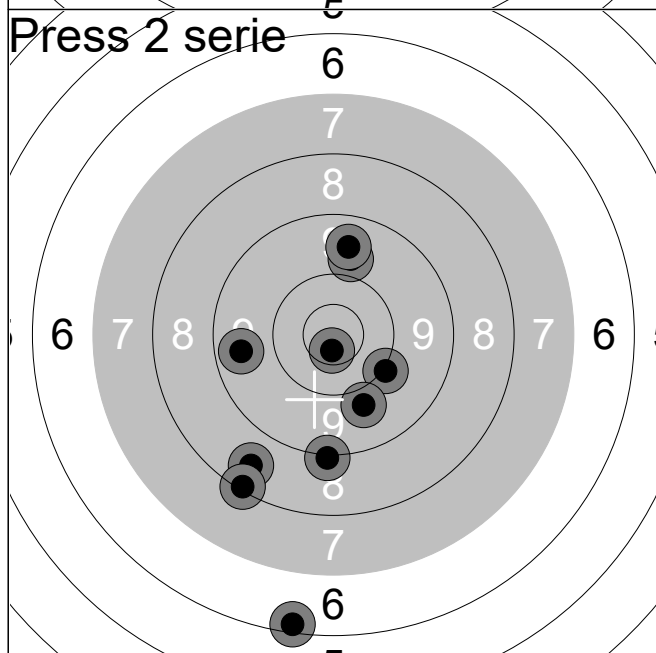

13.3s	9.6	←
56.0s	10.1	↘
1:41m	10.7x	↓
2:45m	9.9	↓
3:27m	8.6	↙
21.5s	9.8	↑
56.5s	8.2	↙
1:51m	9.7	↑
2:26m	9.1	↓
3:07m	6.3	↓
Serie	87 (1x)	
Total	172 (1x)	

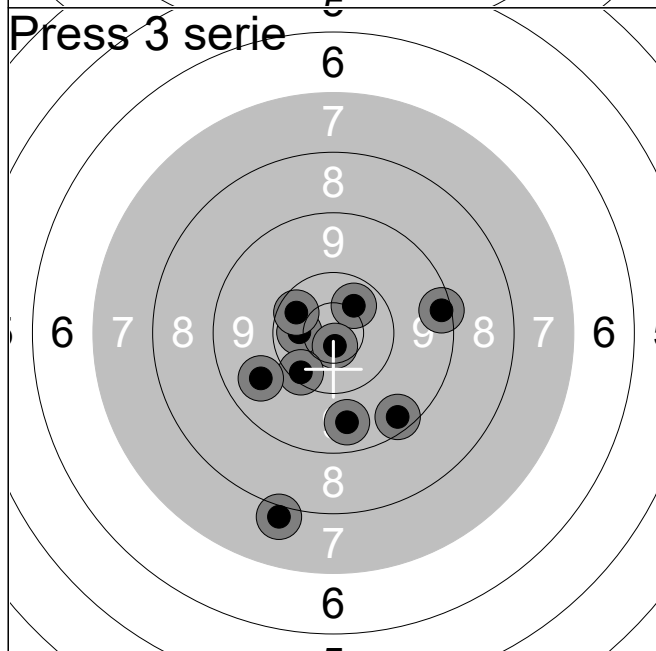

23.2s	8.0	↓
57.0s	9.4	↘
1:34m	9.3	→
2:07m	10.5x	↗
2:54m	9.6	↓
19.8s	10.5x	←
52.3s	10.8x	↓
1:31m	10.2	↙
2:47m	10.4	↙
3:32m	9.7	↙
Serie	94 (3x)	
Total	266 (4x)	

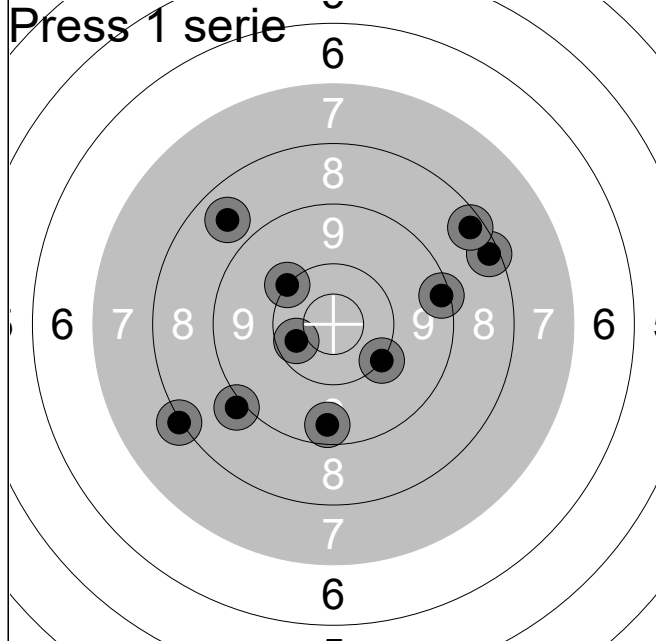

23.0s	10.1	↘
43.5s	8.3	→
1:06m	9.3	→
1:24m	8.1	↙
1:44m	9.5	↓
20.1s	10.1	↗
42.5s	9.0	↙
1:01m	10.4x	←
1:28m	8.7	↗
1:49m	8.3	↗

Serie	89 (1x)
Total	89 (1x)

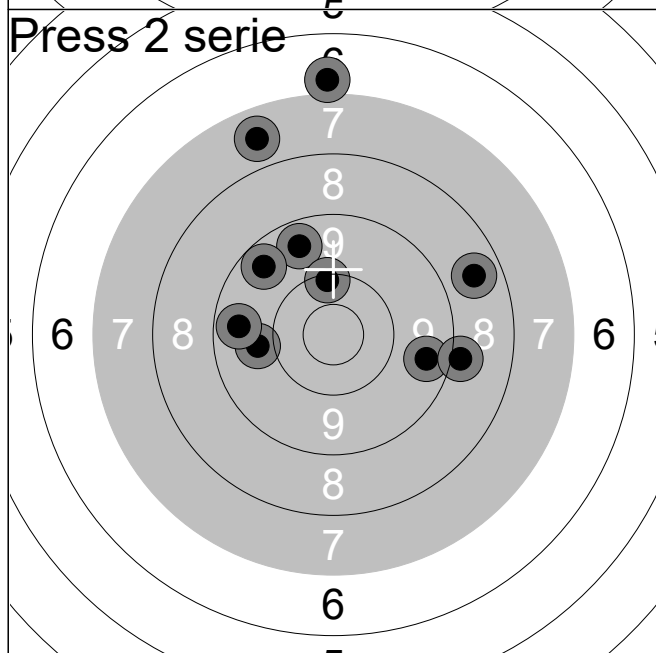

22.9s	9.9	←
45.3s	9.5	→
1:07m	8.6	→
1:24m	9.0	→
1:41m	9.6	↑
19.7s	9.6	←
34.8s	9.5	↗
55.0s	6.9	↑
1:09m	10.2	↑
1:32m	7.6	↑

Serie	85 (0x)
Total	174 (1x)

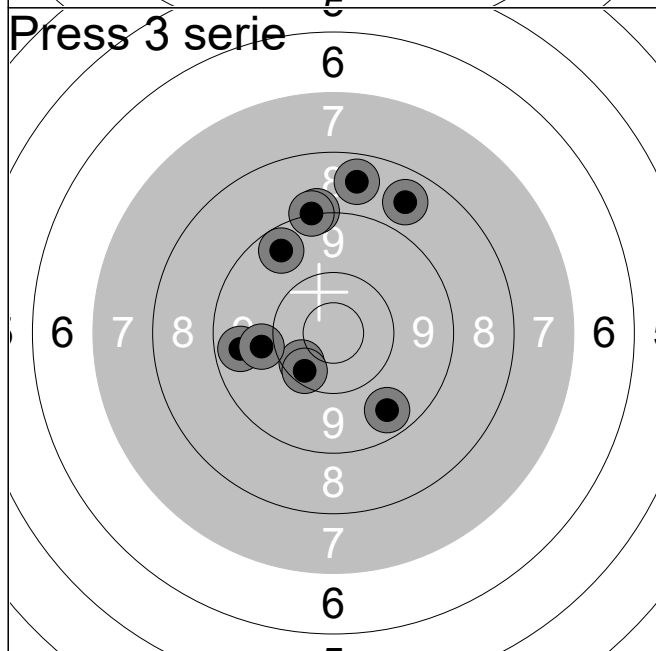

13.7s	8.6	↑
31.2s	8.7	↗
43.7s	10.3	↙
1:00m	9.6	↓
1:20m	9.6	←
35.6s	10.3	↙
49.5s	9.1	↑
1:05m	9.9	←
1:21m	9.5	↗
1:43m	9.1	↑

Serie	90 (0x)
Total	264 (1x)

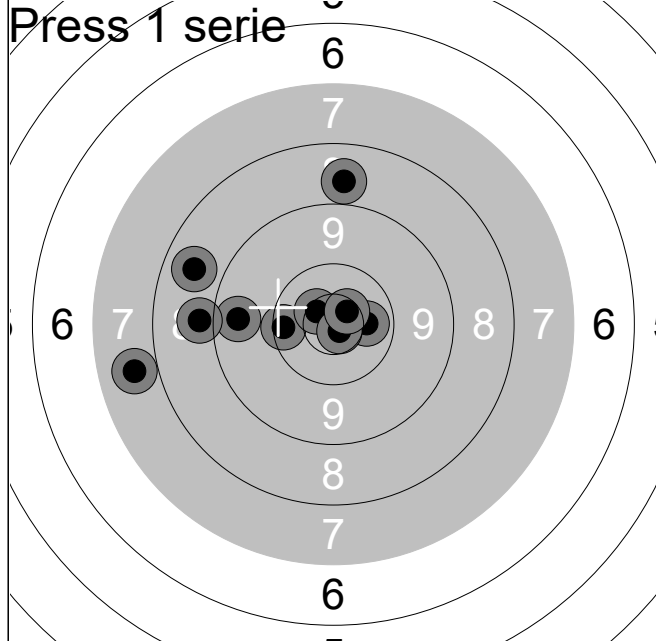

13.5s	8.8	↑
43.4s	9.6	←
1:21m	8.7	↖
2:10m	10.3	←
2:46m	10.7x	↖
13.1s	8.9	←
43.7s	10.5x	→
1:17m	10.8x	↘
1:47m	7.7	←
2:15m	10.7x	↗
Serie	90 (4x)	
Total	90 (4x)	

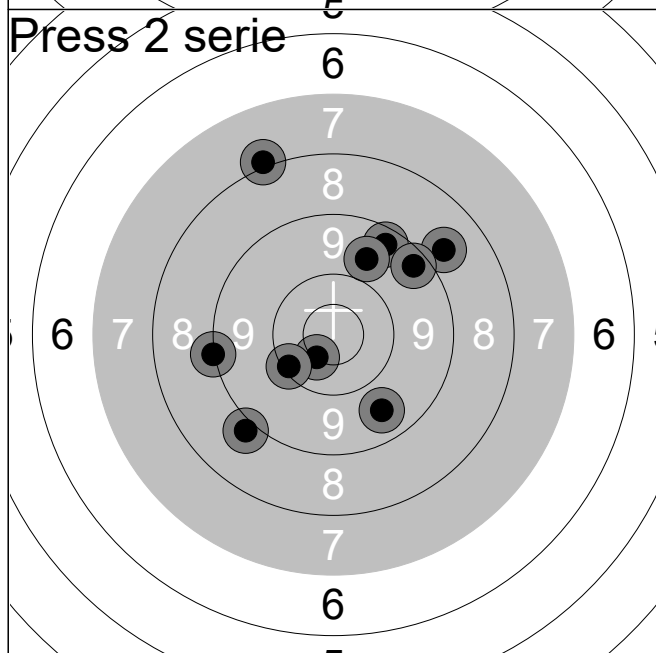

11.3s	8.0	↑
41.3s	8.8	↗
1:09m	10.6x	↘
1:41m	9.0	↘
2:39m	9.4	↑
13.0s	9.1	←
49.7s	10.2	↖
1:26m	9.4	↗
2:04m	9.7	↘
2:43m	9.8	↑
Serie	90 (1x)	
Total	180 (5x)	

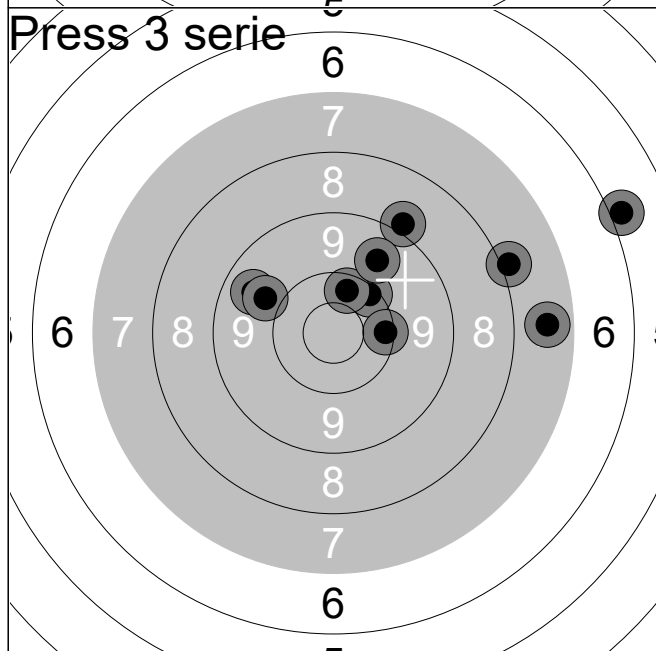

12.2s	9.6	↖
49.4s	7.6	→
1:17m	10.2	↗
1:53m	10.2	→
2:57m	8.0	↗
32.8s	6.0	↗
1:24m	9.9	↖
1:56m	10.3	↑
2:28m	9.0	↗
3:05m	9.7	↑
Serie	87 (0x)	
Total	267 (5x)	

Lag 1	Skive 10	Målfrid Pernille Vannebo		
Grovpistol Press		Numedal SSK		V55
25.06.2019		NM bane 2019		NM Pistol 2019
Press 1 serie 	6	17.5s	9.3	↙
	7	42.8s	9.2	←
	8	1:04m	10.0	→
	9	1:58m	10.4	→
	10	2:22m	10.0	←
	9	32.1s	9.5	←
	8	52.3s	9.6	←
	7	1:16m	10.2	↘
	6	1:40m	10.7x	↗
	5	2:03m	7.9	↓
Serie		93 (1x)		
Total		93 (1x)		
Press 2 serie 	6	20.2s	6.7	↘
	7	38.3s	8.9	↖
	8	1:02m	10.6x	↓
	9	1:22m	10.0	↖
	10	1:56m	9.4	↓
	9	16.2s	9.8	→
	8	36.0s	8.6	←
	7	1:01m	8.1	←
	6	1:21m	10.3	↗
	5	1:48m	7.4	↓
Serie		85 (1x)		
Total		178 (2x)		
Press 3 serie 	6	19.9s	9.8	↖
	7	41.6s	9.7	↗
	8	1:06m	10.1	↗
	9	1:30m	10.6x	↑
	10	2:02m	8.5	↑
	9	20.8s	8.8	↓
	8	45.2s	10.4x	↓
	7	1:32m	10.2	↓
	6	1:59m	10.0	↓
	5	2:28m	9.5	←
Serie		93 (2x)		
Total		271 (4x)		

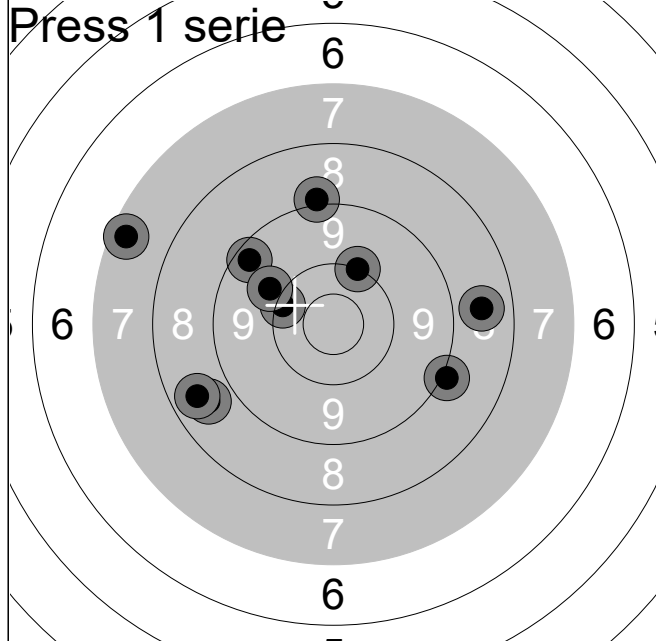

16.4s	8.7	↙
44.9s	10.2	↖
1:08m	8.7	→
1:35m	8.6	↙
2:08m	9.4	↗
18.6s	7.4	↖
43.9s	9.9	↗
1:06m	9.1	↘
1:34m	9.0	↑
2:05m	10.1	↑
Serie		87 (0x)
Total		87 (0x)

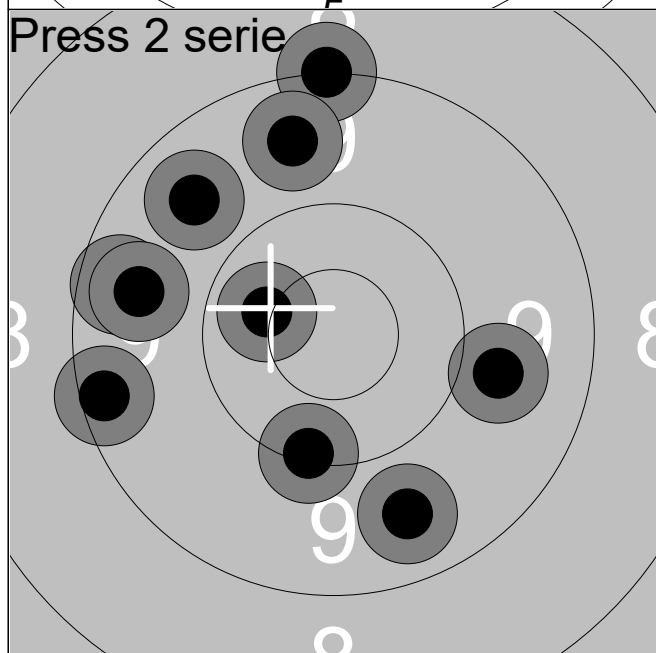

58.3s	9.3	↖
1:28m	9.1	↑
1:54m	10.2	↓
2:18m	9.8	→
2:50m	9.7	↗
23.4s	9.5	↖
50.5s	9.6	↑
1:22m	9.6	↖
1:54m	10.5x	↖
2:22m	9.7	↓
Serie		92 (1x)
Total		179 (1x)

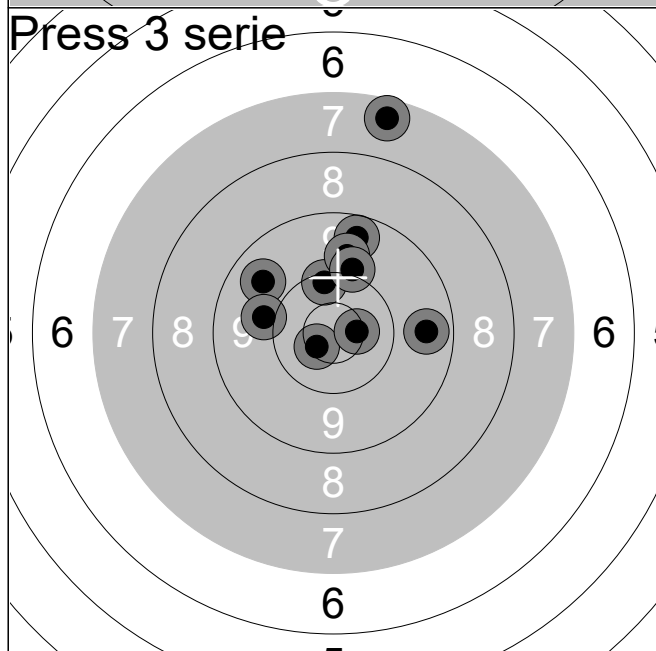

19.9s	10.2	↑
49.5s	10.6x	↙
1:19m	9.6	→
1:48m	9.5	↑
2:22m	9.7	↖
53.7s	10.0	↖
1:24m	7.5	↑
1:59m	10.6x	→
2:30m	9.8	↑
3:03m	10.0	↑
Serie		93 (2x)
Total		272 (3x)

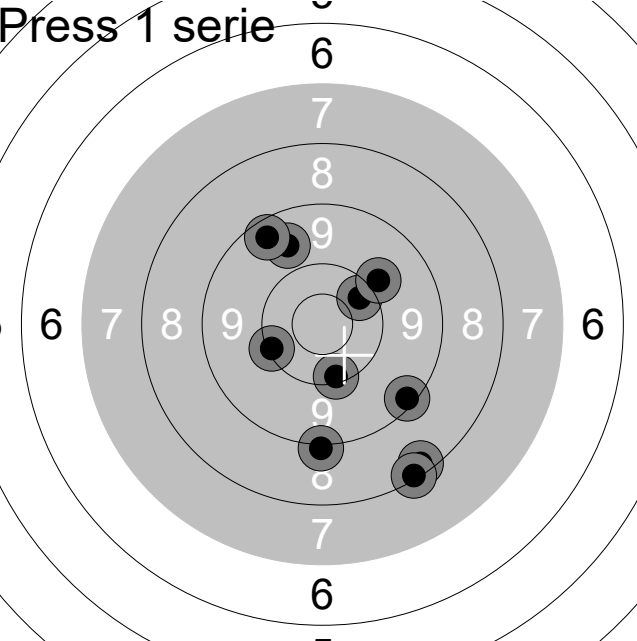
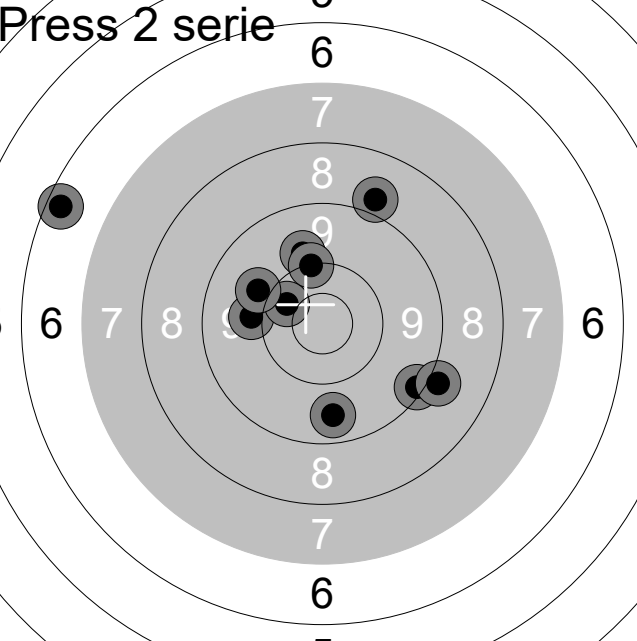
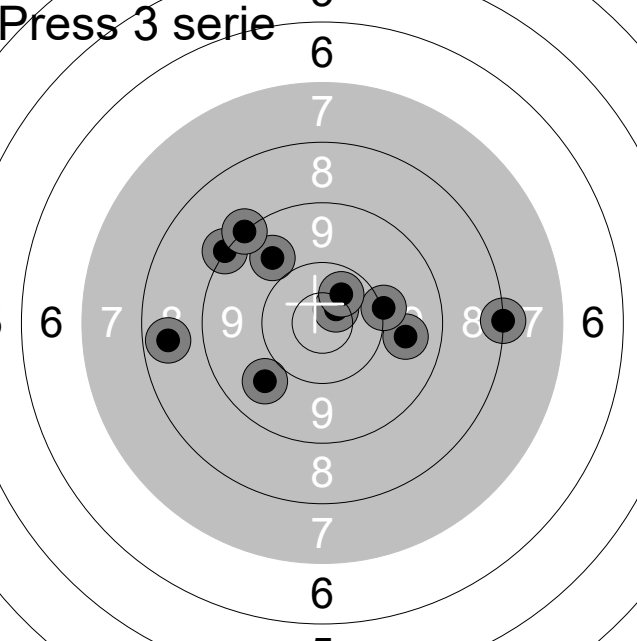
Lag 1	Skive 13	Tom Buene		
Grovpistol Press		Vaksdal SSK		V55
25.06.2019		NM bane 2019		NM Pistol 2019
Press 1 serie		17.3s	9.7	↗
		39.6s	9.3	↘
		59.9s	10.2	↖
		1:21m	10.3	↗
		1:47m	8.3	↘
		22.3s	8.2	↘
		41.7s	9.1	↓
		1:01m	10.2	↘
		1:46m	9.4	↗
		2:08m	10.0	↗
		Serie	92 (0x)	
		Total	92 (0x)	
Press 2 serie		35.1s	9.3	↘
		56.1s	9.0	↘
		1:17m	10.0	↖
		1:38m	10.4x	↗
		2:00m	9.9	↑
		39.1s	8.9	↑
		56.2s	9.9	↖
		1:19m	6.4	↖
		1:38m	9.6	↓
		2:00m	10.1	↑
		Serie	89 (1x)	
		Total	181 (1x)	
Press 3 serie		18.7s	9.1	↖
		39.9s	10.7x	↗
		58.5s	9.7	→
		1:38m	9.8	↗
		2:19m	8.1	→
		35.3s	8.6	↖
		1:14m	9.1	↗
		1:33m	10.1	→
		1:52m	9.8	↘
		2:13m	10.5x	↗
		Serie	91 (2x)	
		Total	272 (3x)	

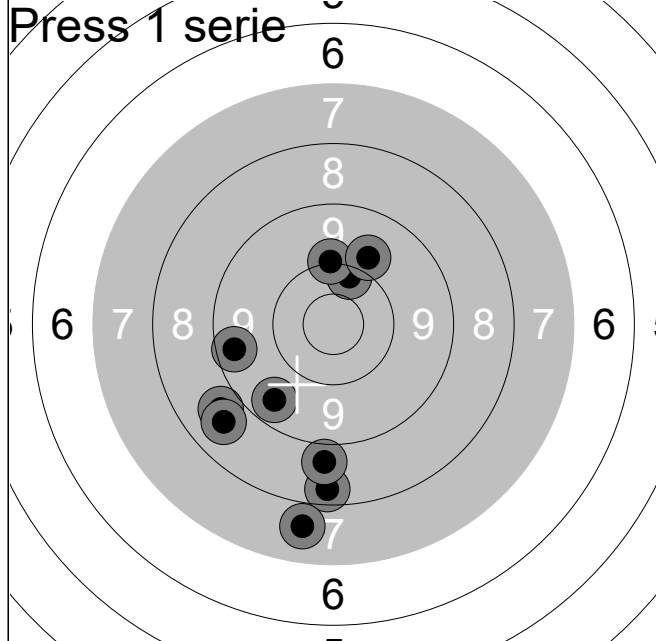

39.2s	8.4	↓
1:04m	9.5	↙
2:13m	10.2	↑
2:32m	9.4	←
2:53m	8.8	↙
37.2s	10.1	↑
1:15m	8.9	↓
1:35m	8.7	↙
1:59m	9.9	↗
2:23m	7.7	↓
Serie	86 (0x)	
Total	86 (0x)	

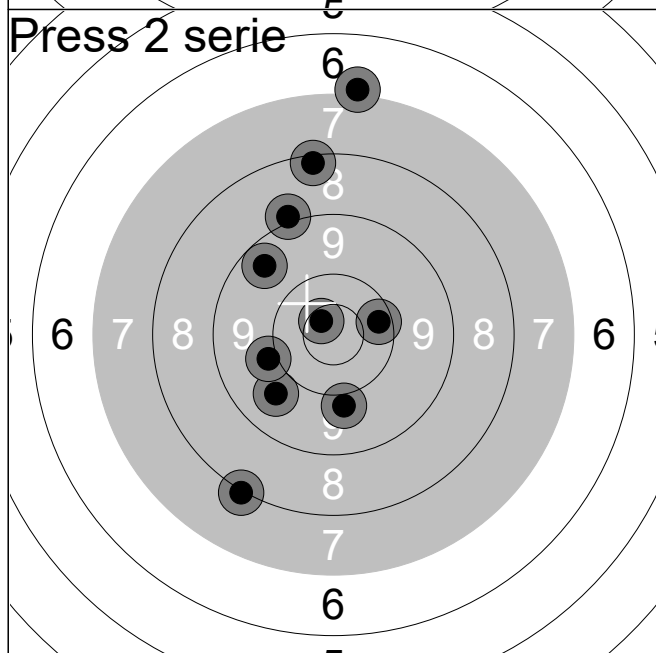

27.6s	8.1	↙
48.0s	9.8	↙
1:08m	7.0	↑
1:32m	10.3	→
1:50m	10.0	←
24.9s	9.0	↑
1:02m	10.7x	↗
1:47m	8.3	↑
2:08m	9.5	↖
2:28m	9.9	↓
Serie	89 (1x)	
Total	175 (1x)	

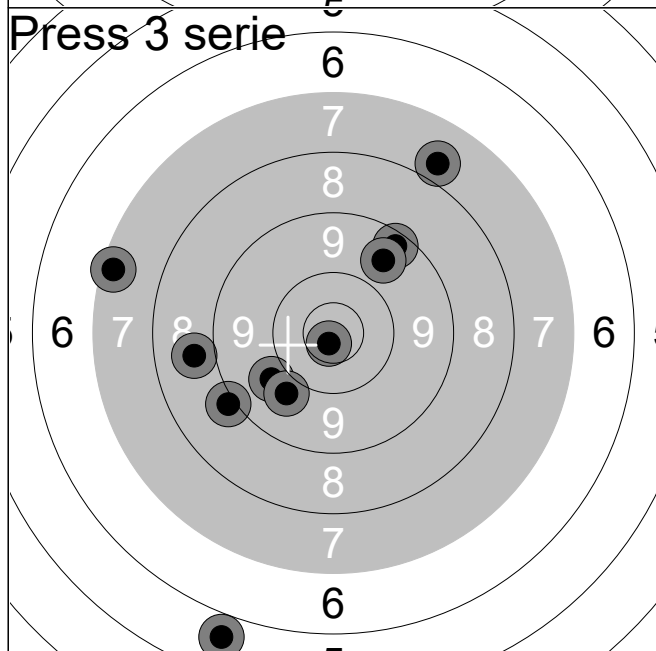

27.4s	8.8	←
46.2s	9.4	↗
1:05m	9.0	↙
1:25m	7.8	↗
1:44m	9.7	↗
40.1s	10.8x	↓
1:00m	7.3	←
1:23m	5.8	↓
1:51m	9.9	↙
2:12m	9.9	↙
Serie	82 (1x)	
Total	257 (2x)	

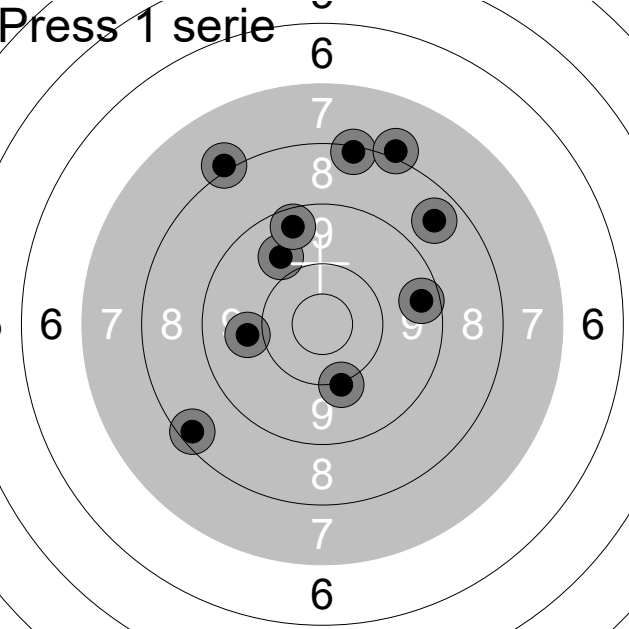
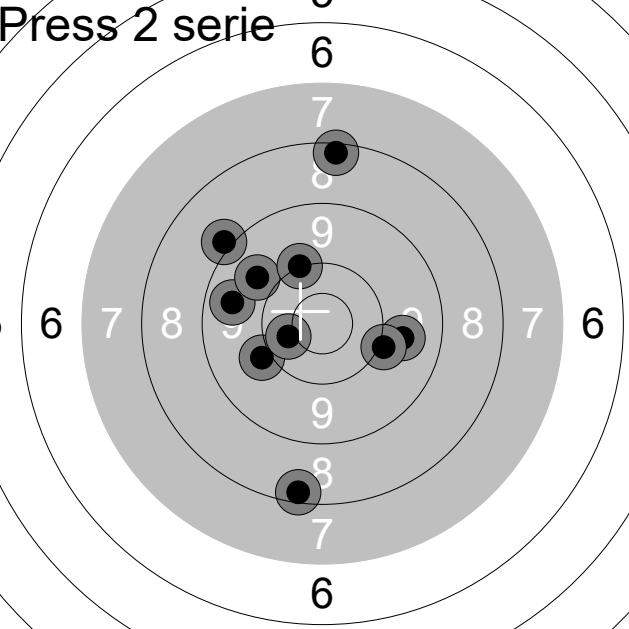
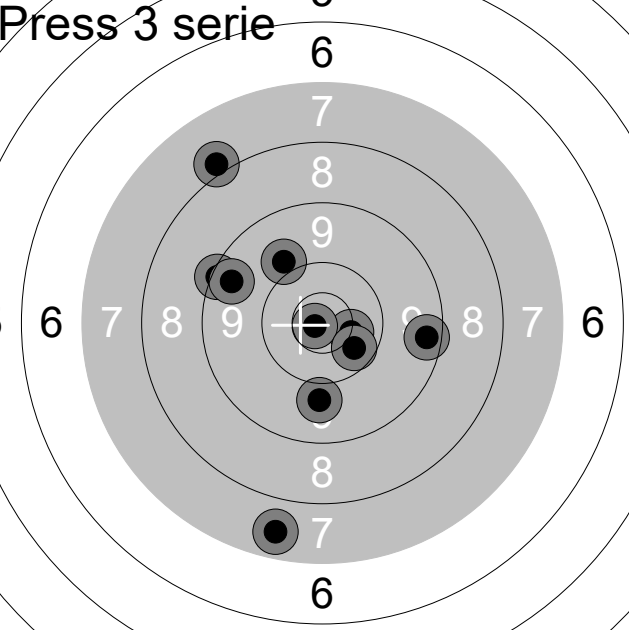
Lag 1	Skive 16	Jakob Kråkevik		
Grovpistol Press		Odda Pk		V65
25.06.2019		NM bane 2019		NM Pistol 2019
Press 1 serie		16.6s	8.2	↑
		36.0s	8.6	↗
		1:15m	8.0	↑
		1:34m	8.0	↗
		1:54m	8.3	↙
		16.4s	9.5	→
		35.4s	9.8	↗
		53.2s	9.9	←
		1:14m	10.1	↘
		1:34m	9.5	↑
		Serie		86 (0x)
		Total		86 (0x)
Press 2 serie		14.0s	10.0	←
		30.8s	10.4x	←
		48.5s	9.6	←
		1:06m	9.8	↗
		1:25m	9.8	→
		31.3s	8.3	↘
		48.4s	10.1	↗
		1:06m	10.0	→
		1:23m	8.3	↑
		1:43m	9.0	↗
		Serie		92 (1x)
		Total		178 (1x)
Press 3 serie		17.2s	9.4	→
		36.4s	10.5x	→
		54.4s	10.8x	←
		1:11m	9.2	↗
		1:29m	9.5	↗
		11.2s	10.4x	↘
		27.4s	7.6	↘
		45.0s	9.9	↘
		1:01m	9.9	↗
		1:22m	8.0	↗
		Serie		90 (3x)
		Total		268 (4x)

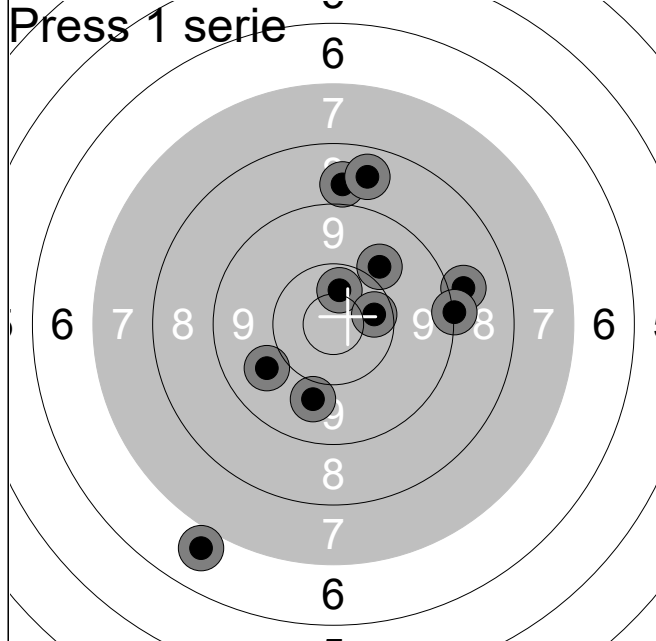

12.4s	8.8	↑
37.9s	9.9	↗
1:00m	10.5x	↑
1:22m	10.4	→
1:45m	9.8	↖
16.3s	8.9	→
37.9s	9.8	↓
59.8s	9.1	→
1:19m	6.8	↙
1:35m	8.6	↑
Serie	86 (1x)	
Total	86 (1x)	

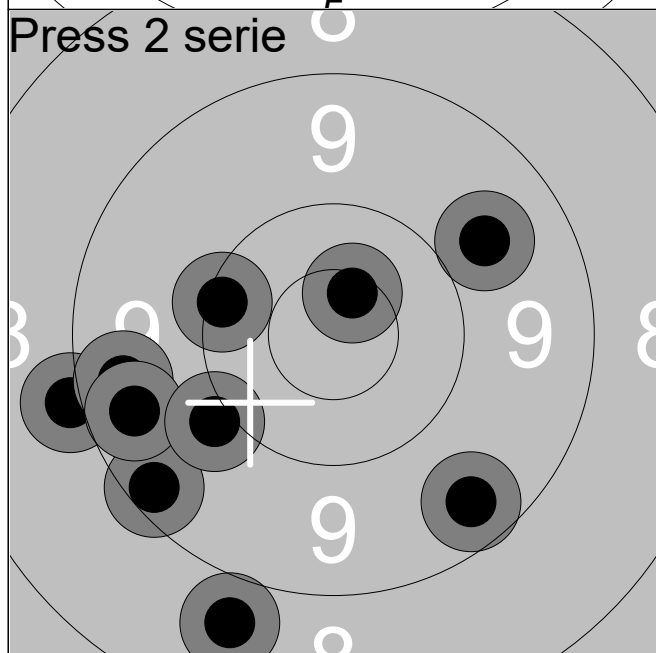

11.9s	10.2	↖
31.2s	9.3	↙
55.1s	9.8	↗
1:18m	9.1	↖
1:40m	9.5	↖
13.1s	9.5	↘
30.6s	9.5	↖
46.8s	10.0	↖
1:07m	10.7x	↑
1:23m	8.8	↓
Serie	92 (1x)	
Total	178 (2x)	

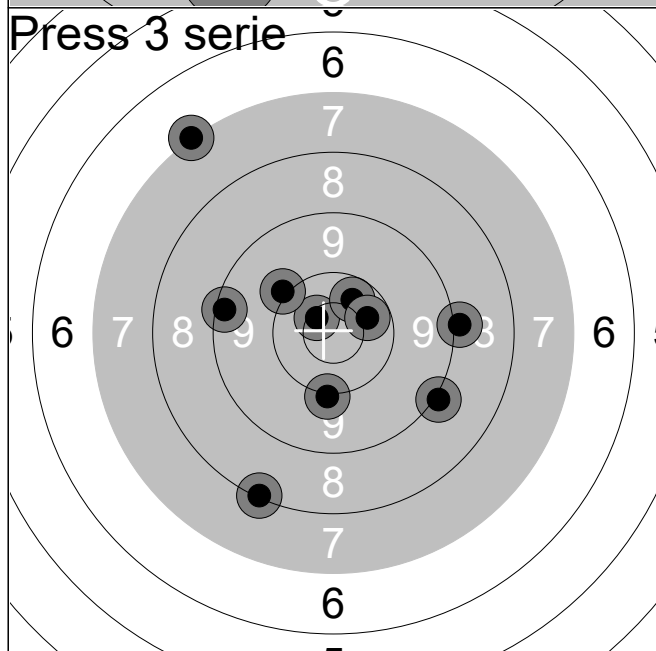

13.8s	9.0	→
32.2s	10.6x	↖
54.3s	10.4x	↗
1:12m	10.4x	→
1:29m	10.0	↖
10.4s	10.1	↓
29.5s	9.3	↖
46.8s	7.1	↗
1:10m	9.1	↘
1:24m	8.2	↓
Serie	92 (3x)	
Total	270 (5x)	

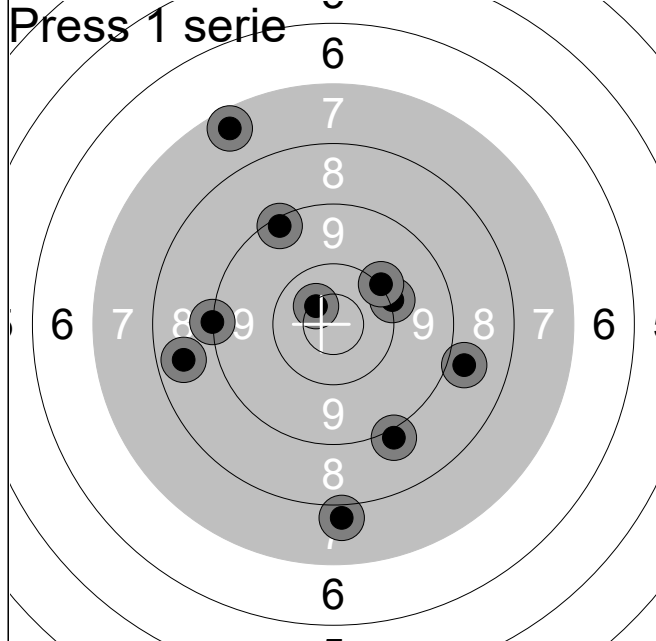

13.2s	7.5	↗
42.3s	10.6x	↗
1:13m	9.1	←
1:50m	9.0	↘
2:30m	9.3	↗
14.0s	8.9	→
47.9s	10.1	↗
1:19m	8.6	←
1:56m	10.1	↗
2:36m	7.9	↓
Serie		87 (1x)
Total		87 (1x)

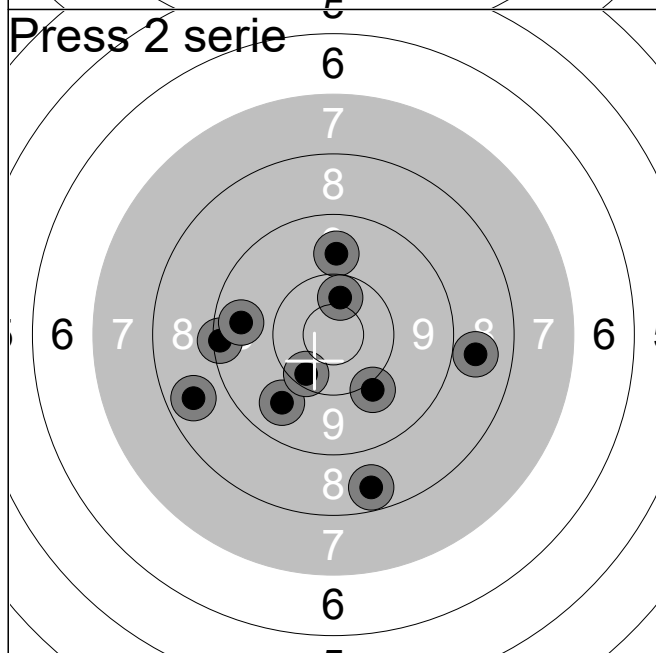

17.1s	9.8	↑
48.7s	10.4x	↑
1:27m	8.5	↓
2:00m	9.7	↓
2:34m	9.3	←
14.3s	8.6	←
51.9s	10.3	↓
1:24m	9.6	←
2:04m	10.0	↓
2:37m	8.8	→
Serie		90 (1x)
Total		177 (2x)

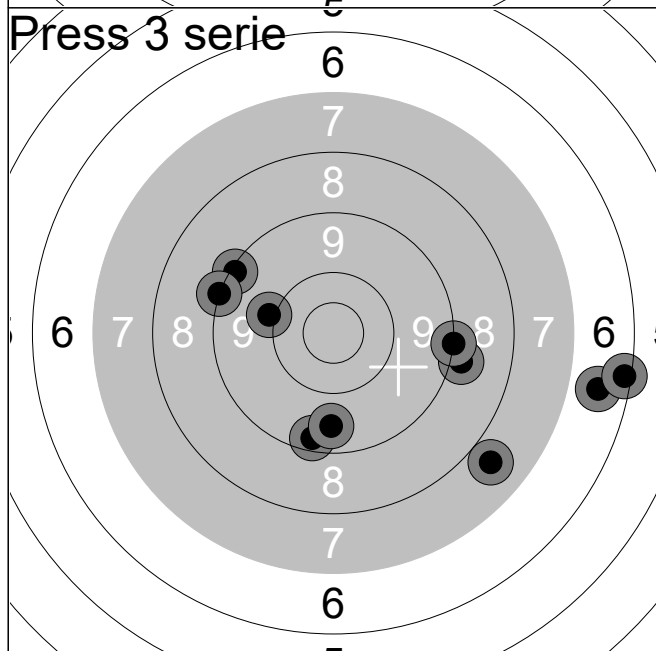

13.1s	6.6	→
48.2s	6.2	→
1:29m	9.0	→
2:05m	7.8	↘
2:41m	9.2	↗
21.7s	9.1	←
49.5s	9.4	↓
1:29m	9.6	↓
2:10m	9.1	→
2:37m	10.0	←
Serie		83 (0x)
Total		260 (2x)

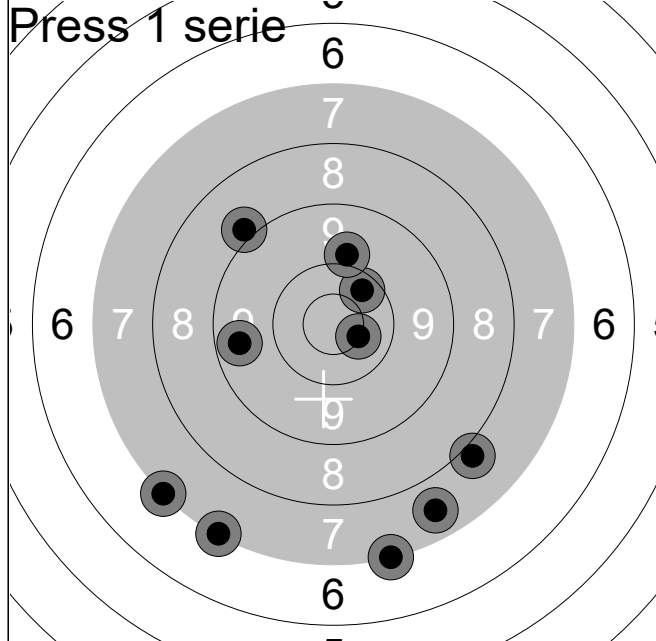

17.9s	7.2	↘
44.8s	7.1	↘
1:17m	9.5	←
2:01m	7.1	↘
2:27m	8.0	↘
12.8s	7.6	↘
51.4s	10.3	↗
1:20m	9.0	↗
1:46m	10.0	↑
2:19m	10.6x	→
Serie	84 (1x)	
Total	84 (1x)	

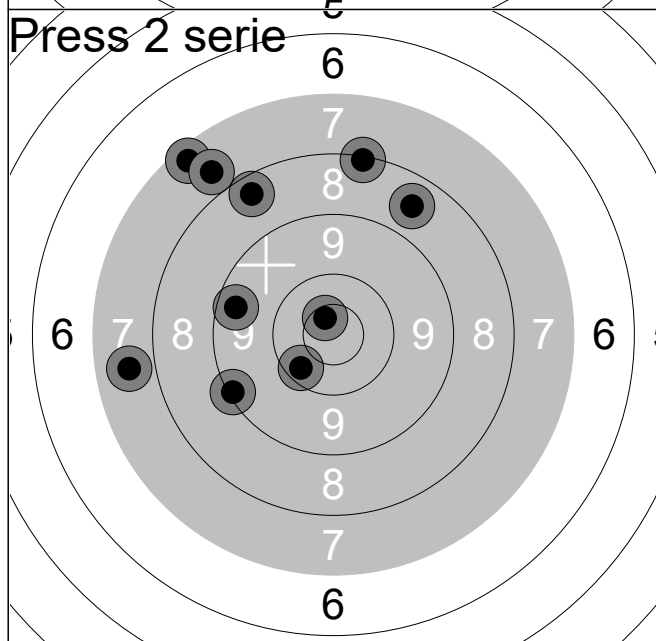

17.2s	9.2	←
42.6s	10.7x	↗
1:15m	7.4	↗
1:47m	9.5	←
2:22m	8.6	↗
18.8s	7.8	↗
44.7s	10.3	↘
1:43m	8.4	↗
2:11m	8.2	↑
2:58m	7.7	←
Serie	83 (1x)	
Total	167 (2x)	

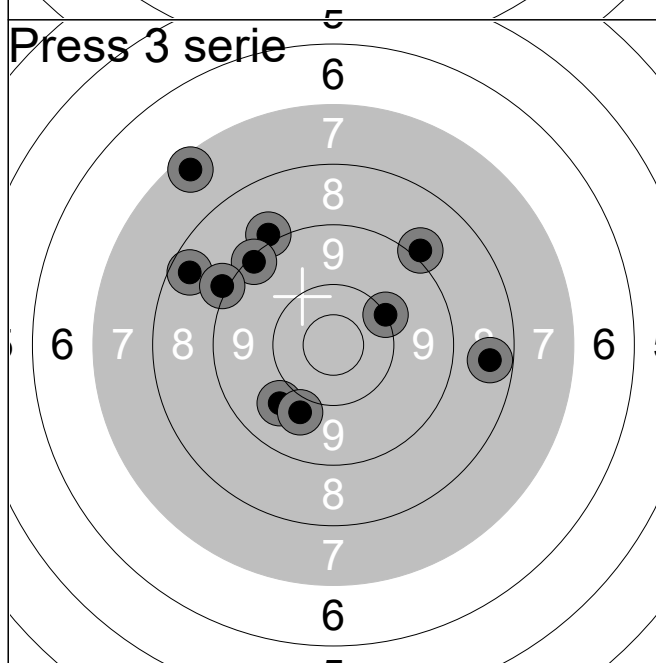

18.4s	7.4	↗
51.4s	8.5	↖
1:24m	8.5	→
1:54m	9.8	↘
2:19m	9.0	↗
13.7s	9.0	↗
39.6s	10.1	↗
1:06m	9.2	↗
1:31m	9.0	↖
2:17m	9.9	↘
Serie	87 (0x)	
Total	254 (2x)	

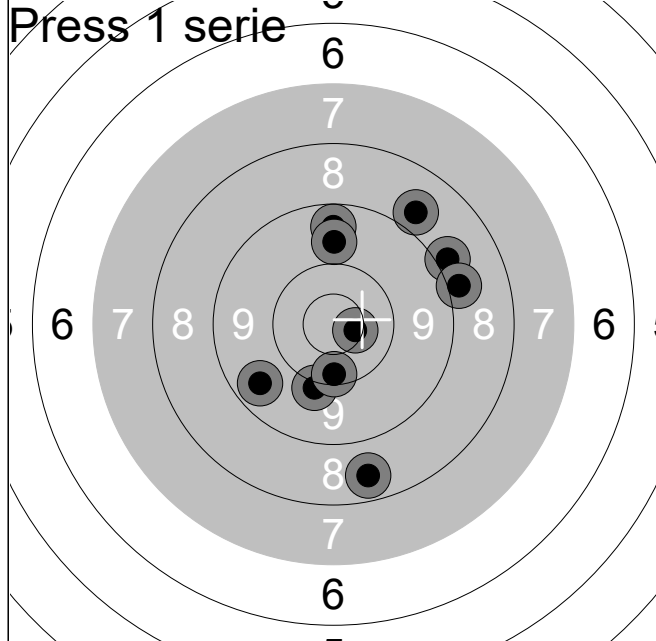

14.8s	10.0	↓
47.5s	8.6	↓
1:37m	9.0	↗
1:57m	9.0	→
2:21m	8.8	↗
11.6s	9.5	↑
1:30m	9.6	↖
1:51m	10.3	↓
2:10m	10.6x	→
2:51m	9.8	↑

Serie	91 (1x)
-------	----------

Total	91 (1x)
-------	----------

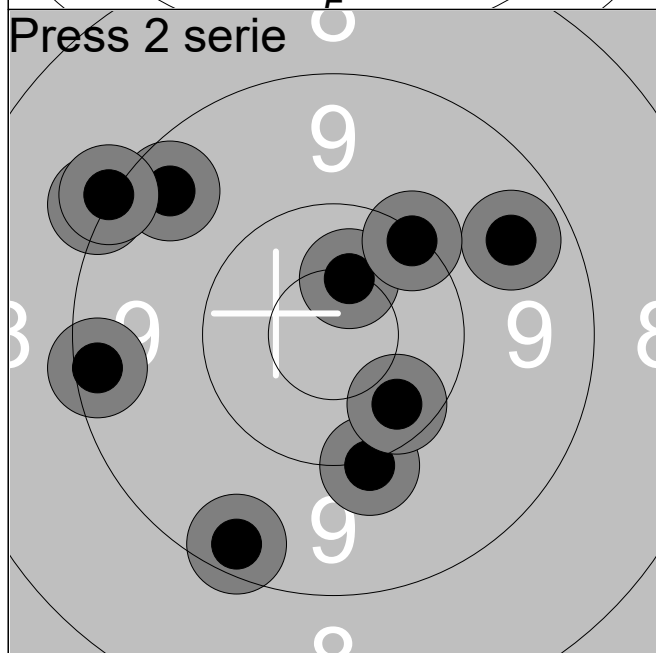

9.86s	9.6	↗
29.3s	9.1	↖
1:18m	9.4	↓
1:41m	10.1	↓
2:01m	9.3	←
11.4s	9.5	↗
31.3s	10.3	↘
1:23m	10.6x	↑
1:46m	10.2	↗
2:29m	9.1	↖

Serie	94 (1x)
-------	----------

Total	185 (2x)
-------	-----------

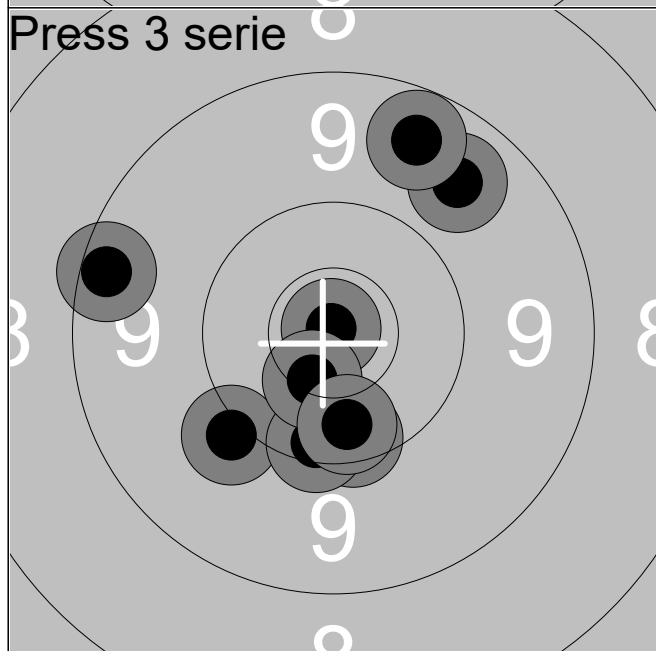

12.2s	10.3	↓
39.5s	10.0	↖
1:05m	10.9x	↗
2:32m	9.3	←
2:50m	9.6	↗
10.1s	10.3	↓
1:29m	9.5	↗
1:46m	10.2	↓
2:03m	10.6x	↘
2:22m	10.4	↓

Serie	97 (2x)
-------	----------

Total	282 (4x)
-------	-----------

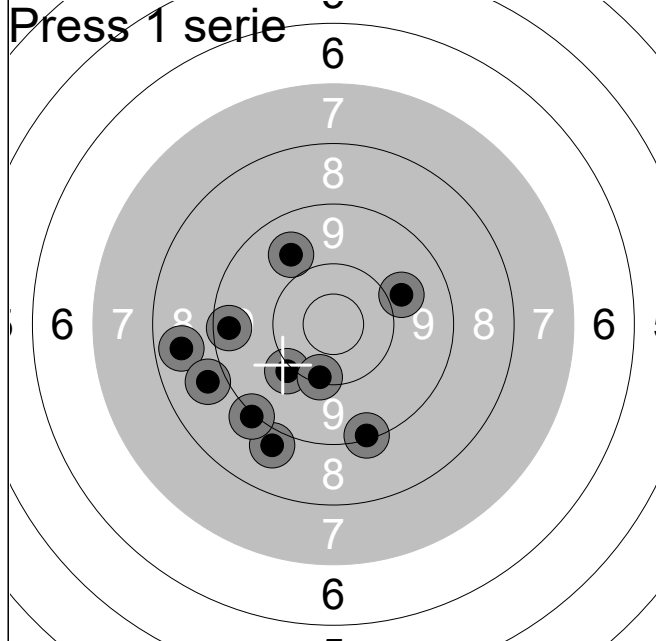

14.9s	8.6	←
21.4s	9.8	↗
54.9s	8.8	←
1:27m	9.2	↓
1:32m	9.4	←
14.5s	9.9	↗
19.1s	8.9	↓
45.0s	10.0	↙
51.4s	9.1	↙
1:37m	10.2	↓
Serie	89 (0x)	
Total	89 (0x)	

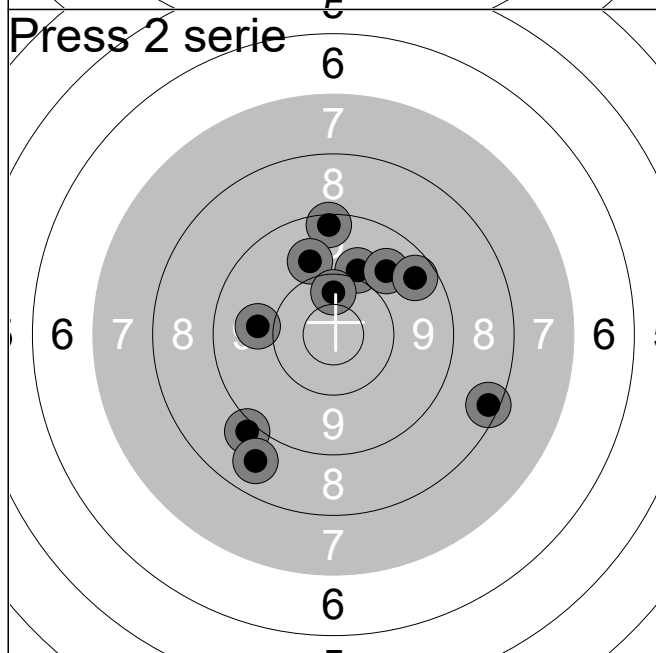

16.6s	10.0	↑
32.4s	8.3	→
41.3s	9.0	↙
1:01m	9.3	↑
1:05m	9.8	↗
17.4s	9.5	↗
22.9s	9.9	←
28.5s	9.9	↑
57.5s	10.4	↑
1:34m	8.7	↙
Serie	90 (0x)	
Total	179 (0x)	

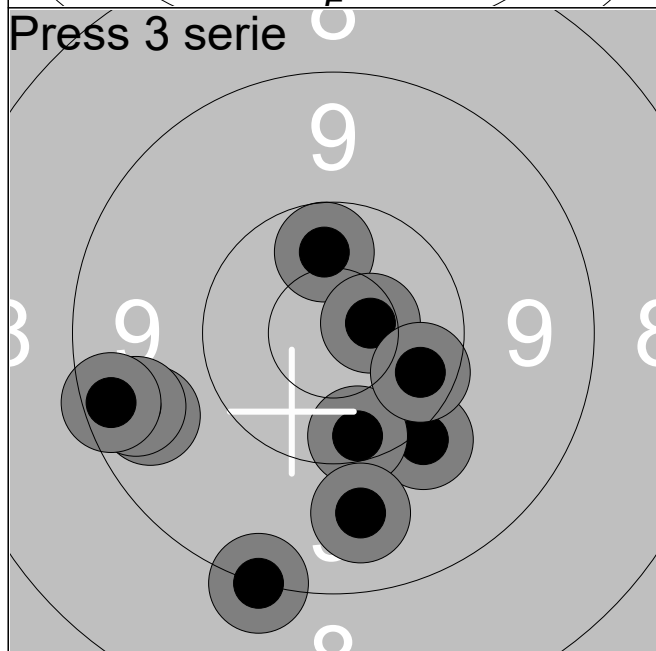

15.5s	10.4x	↑
40.2s	10.7x	→
1:11m	10.1	↙
2:01m	10.3	↓
2:31m	9.1	↓
16.6s	9.7	↓
46.7s	10.3	→
54.9s	9.6	←
1:19m	9.5	←
1:56m	9.4	←
Serie	95 (2x)	
Total	274 (2x)	

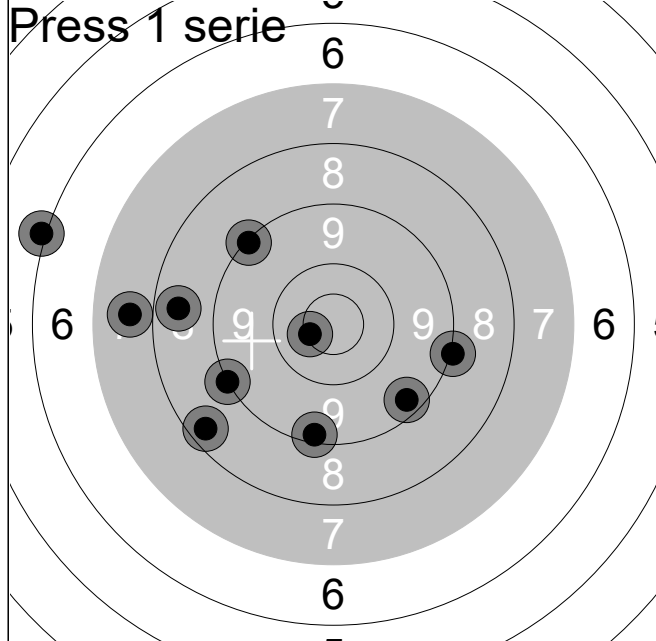

18.1s	10.6x	←
51.4s	9.3	↓
1:30m	9.1	←
2:05m	9.4	↘
2:40m	8.4	←
15.2s	9.1	→
47.9s	7.8	←
1:24m	8.6	←
2:02m	9.2	↗
2:44m	6.1	←
Serie	84 (1x)	
Total	84 (1x)	

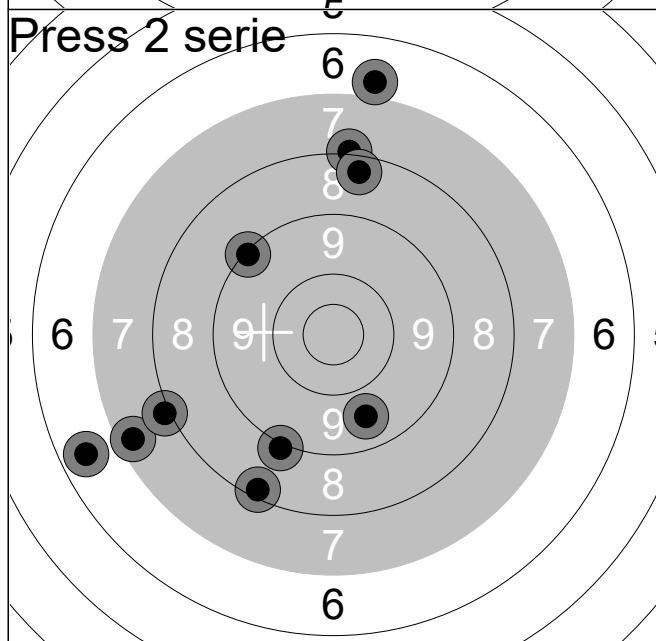

15.6s	8.1	↑
43.8s	9.2	↗
1:15m	7.4	←
1:47m	8.3	↓
2:22m	8.0	←
16.5s	6.6	←
47.8s	8.4	↑
1:22m	9.7	↓
2:00m	6.9	↑
2:37m	9.1	↓
Serie	78 (0x)	
Total	162 (1x)	

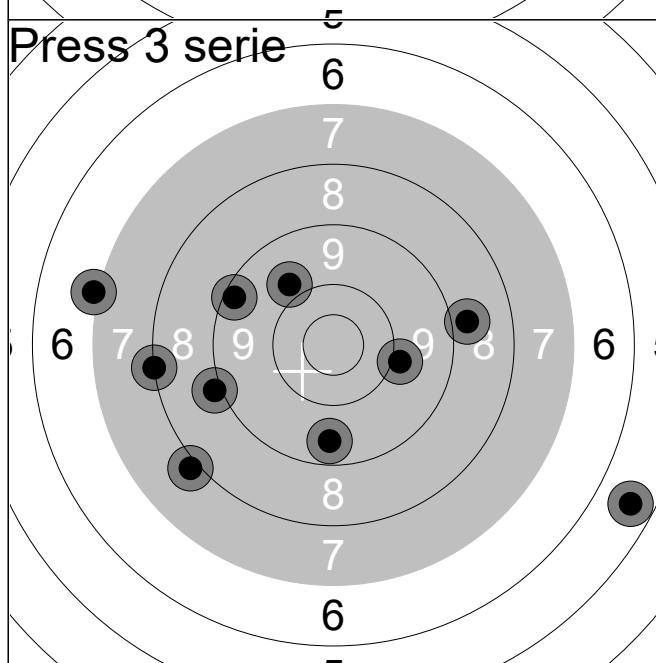

14.1s	8.9	→
46.7s	5.5	↘
1:18m	7.1	←
1:52m	9.0	←
2:26m	8.0	↘
18.2s	10.0	→
52.7s	8.1	←
1:28m	9.3	↖
2:09m	9.9	↗
2:47m	9.5	↓
Serie	82 (0x)	
Total	244 (1x)	

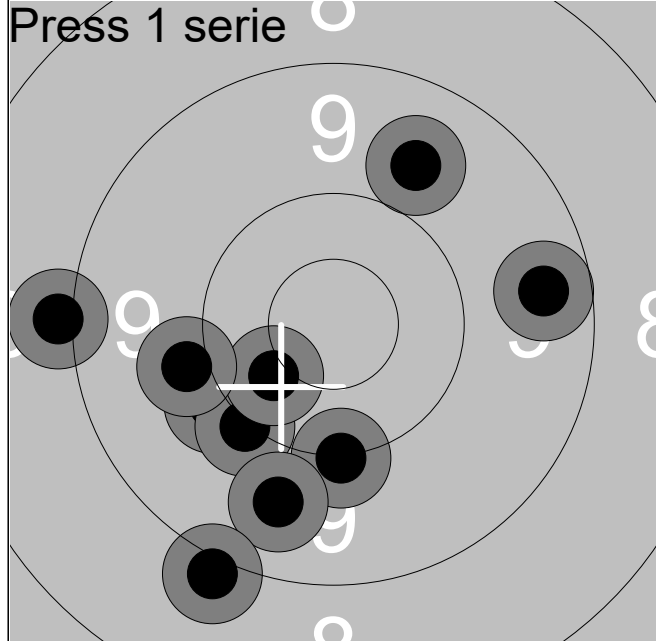

13.7s	10.0	↙
35.5s	10.1	↓
53.7s	9.0	←
1:20m	10.1	↘
1:38m	9.7	↓
16.8s	10.4x	↙
1:02m	9.5	→
1:29m	9.8	↗
1:56m	9.0	↘
3:40m	10.0	←

Serie	95 (1x)
-------	----------

Total	95 (1x)
-------	----------

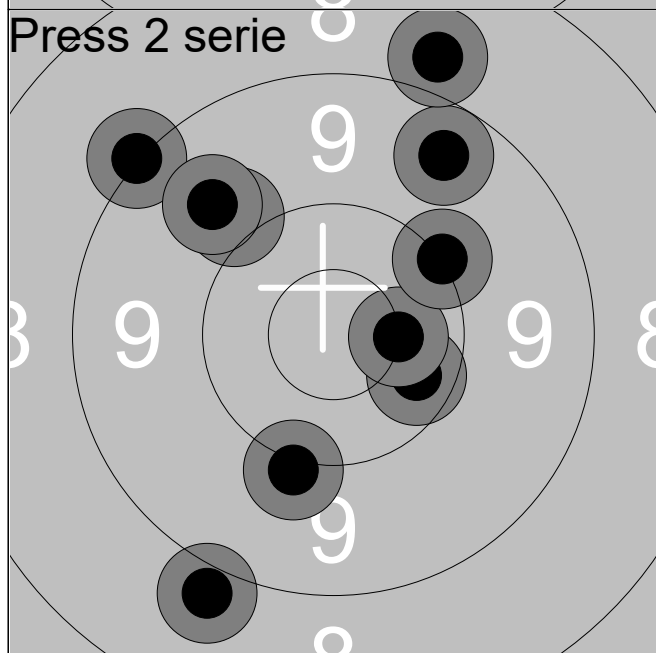

17.1s	10.4	↘
38.2s	10.0	↗
58.6s	9.1	↗
1:30m	10.0	↓
1:55m	8.9	↘
11.9s	9.8	↗
44.2s	10.5x	→
1:31m	9.5	↗
1:51m	8.9	↗
2:14m	10.1	↗

Serie	93 (1x)
-------	----------

Total	188 (2x)
-------	-----------

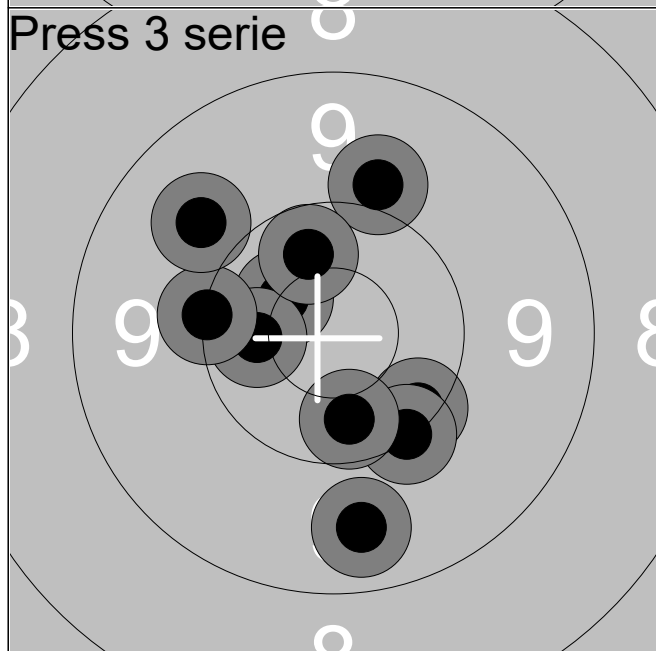

17.6s	10.0	↗
37.3s	10.6x	↖
58.0s	10.5x	←
1:19m	9.6	↓
1:38m	10.2	↘
14.0s	10.1	←
32.6s	9.8	↗
55.3s	10.1	↘
1:15m	10.4x	↓
1:33m	10.4x	↗

Serie	98 (4x)
-------	----------

Total	286 (6x)
-------	-----------

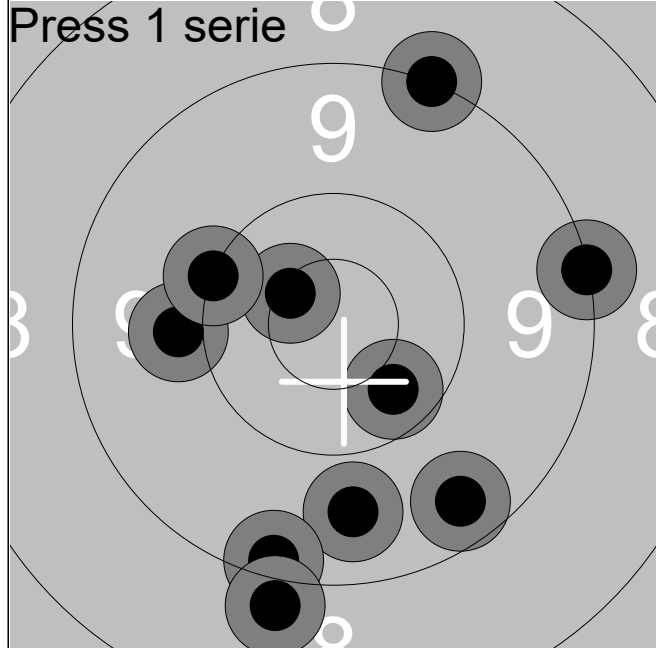

18.9s	10.0	←
54.4s	9.5	↓
1:39m	10.6x	↗
2:21m	9.7	↓
2:58m	10.4x	↓
48.1s	9.1	↗
1:34m	10.1	←
2:16m	9.2	→
3:02m	9.3	↓
3:53m	8.9	↓

Serie 93 (2x)

Total 93 (2x)

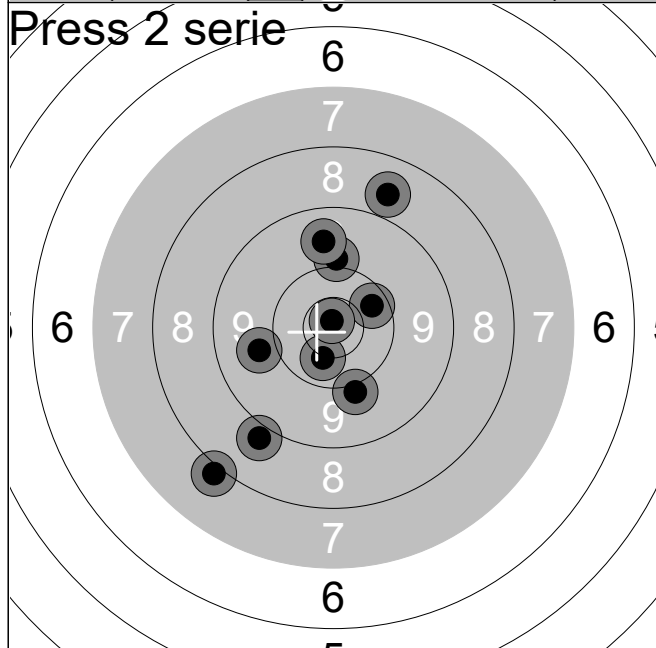

21.8s	10.0	↑
56.4s	9.7	↑
2:30m	8.8	↗
3:00m	9.8	←
3:54m	8.0	↓
18.5s	10.0	↓
1:27m	10.5x	↓
2:07m	8.9	↓
2:54m	10.3	↗
3:53m	10.8x	↑

Serie 92 (2x)

Total 185 (4x)

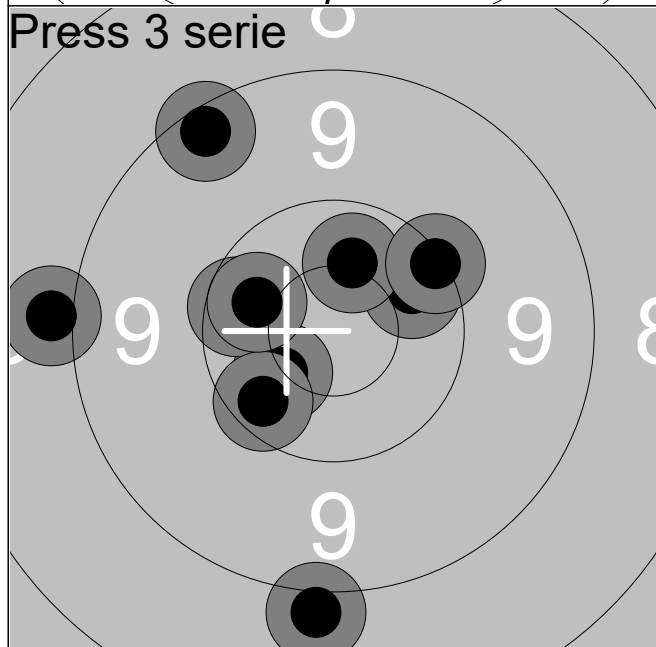

20.2s	9.0	←
1:28m	10.4x	↗
2:09m	10.5x	↙
2:56m	9.0	↓
3:51m	10.3	←
23.8s	10.5x	↑
1:46m	9.3	↗
2:30m	10.3	↙
3:47m	10.4x	←
4:26m	10.2	↗

Serie 97 (4x)

Total 282 (8x)

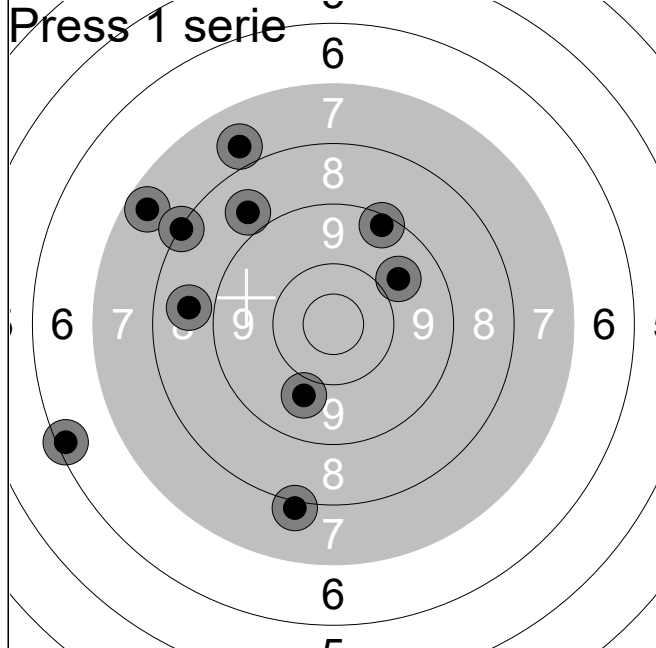

14.8s	7.5	↖
35.5s	9.3	↗
1:09m	8.2	↗
1:36m	7.8	↗
2:03m	9.9	↘
14.1s	8.7	←
38.2s	8.0	↘
59.5s	6.3	←
1:41m	8.8	↗
2:27m	9.8	↗
Serie		79 (0x)
Total		79 (0x)

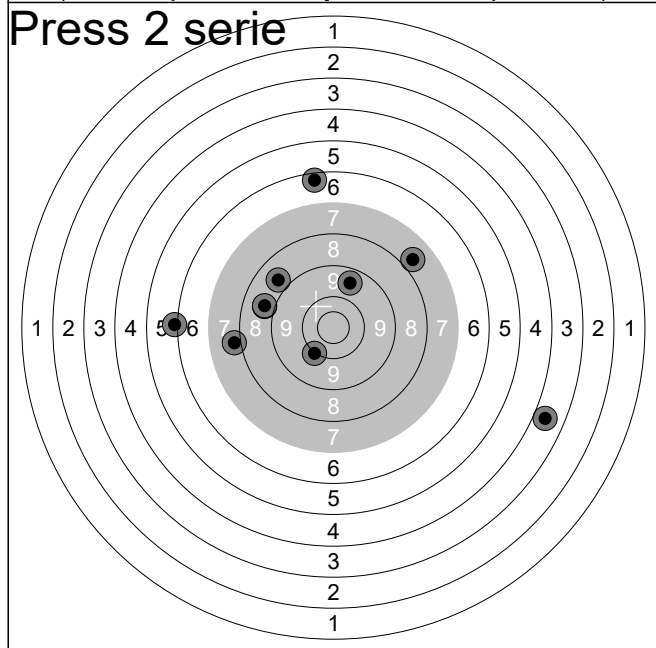

13.6s	6.0	←
36.2s	7.8	↗
1:22m	9.6	↗
2:02m	8.8	←
2:27m	3.8	→
11.0s	7.9	←
36.9s	8.8	←
56.7s	6.4	↑
1:22m	8.8	↗
1:45m	10.1	↘
Serie		72 (0x)
Total		151 (0x)

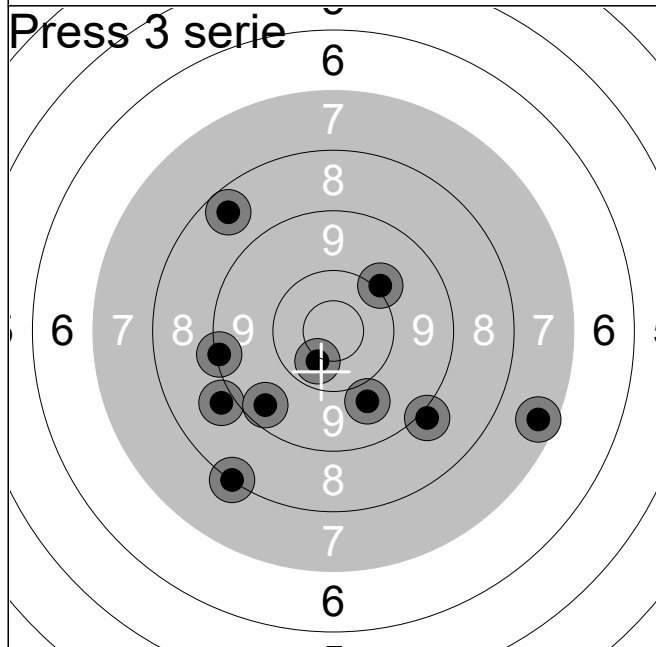

6.57s	8.5	↗
29.6s	10.5x	↘
49.4s	8.9	←
1:08m	7.4	→
1:22m	9.5	↘
8.94s	8.1	↘
33.4s	10.0	↗
55.9s	9.0	↘
1:17m	9.2	←
1:53m	9.8	↘
Serie		87 (1x)
Total		238 (1x)

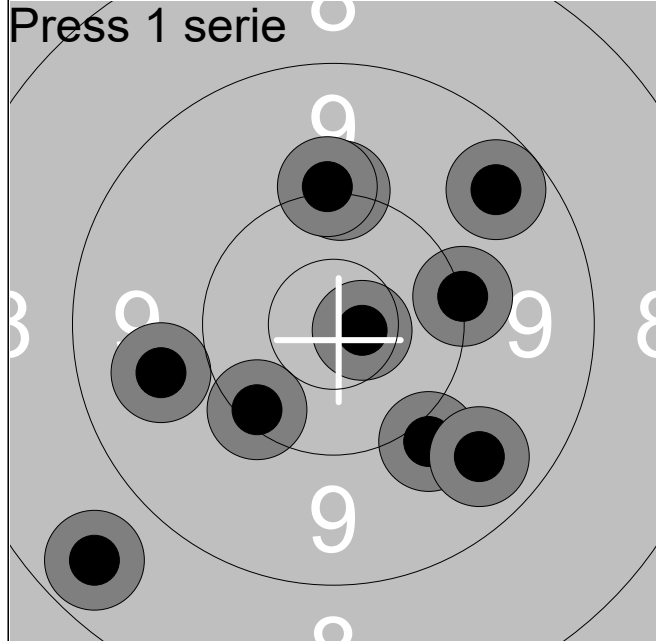

16.4s	10.0	↘
52.6s	10.1	↑
1:28m	9.5	↗
2:05m	10.1	↑
2:43m	8.6	↙
14.2s	10.1	→
48.9s	9.8	←
1:28m	10.2	↙
2:14m	9.6	↘
2:55m	10.8x	→

Serie	95 (1x)
-------	----------

Total	95 (1x)
-------	----------

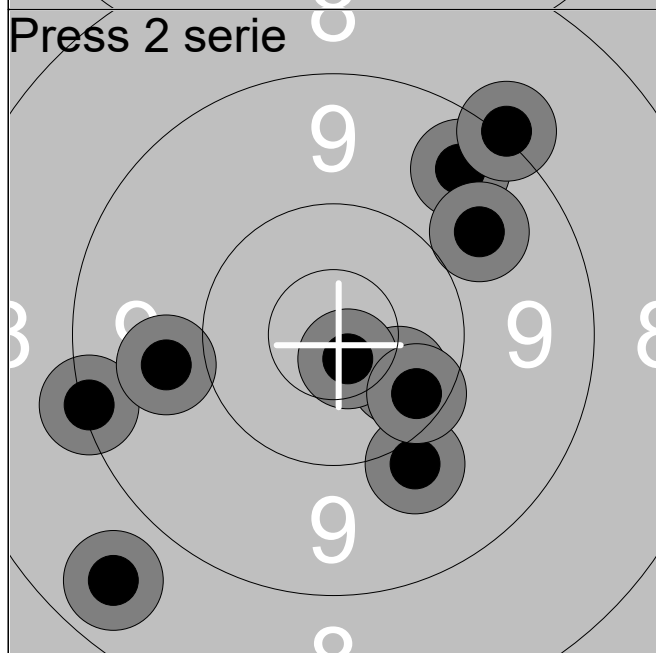

20.3s	9.2	←
1:01m	10.0	↘
1:42m	9.5	↗
2:21m	9.8	↗
2:59m	10.4x	↘
23.1s	9.1	↗
1:04m	10.8x	↘
1:43m	9.8	←
2:26m	8.6	↙
2:57m	10.3	↘

Serie	93 (2x)
-------	----------

Total	188 (3x)
-------	-----------

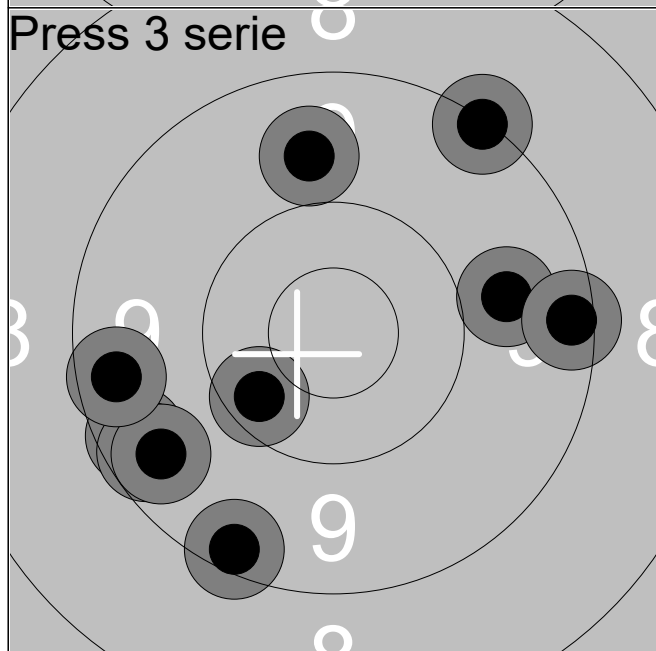

17.9s	9.2	↗
1:07m	9.3	↘
1:40m	9.4	←
2:20m	9.4	↙
2:55m	9.5	↙
30.4s	9.8	↑
1:17m	9.4	←
2:08m	9.8	→
2:52m	10.3	↙
3:29m	9.3	→

Serie	91 (0x)
-------	----------

Total	279 (3x)
-------	-----------

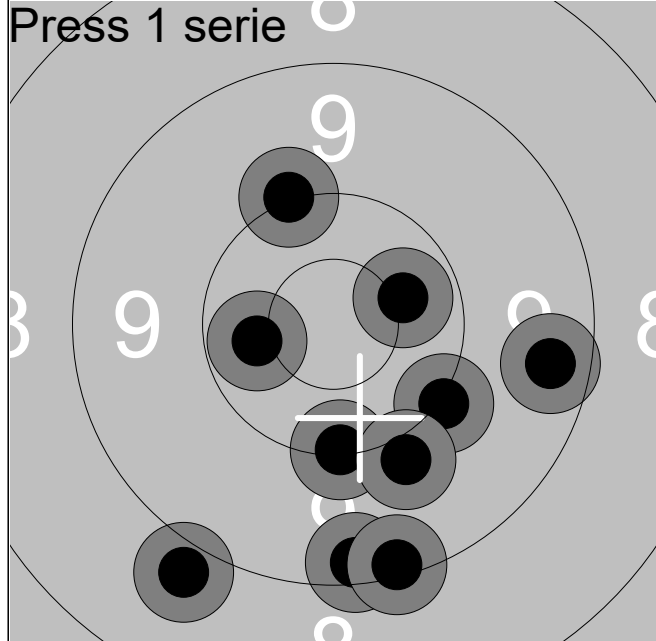

20.3s	10.1	↗
1:18m	10.1	↘
2:25m	10.4x	←
2:57m	10.1	↓
3:32m	9.3	↓
1:19m	9.5	→
1:43m	10.0	↘
2:42m	9.2	↓
3:10m	8.9	↘
4:07m	10.5x	→

Serie 95 (2x)

Total 95 (2x)

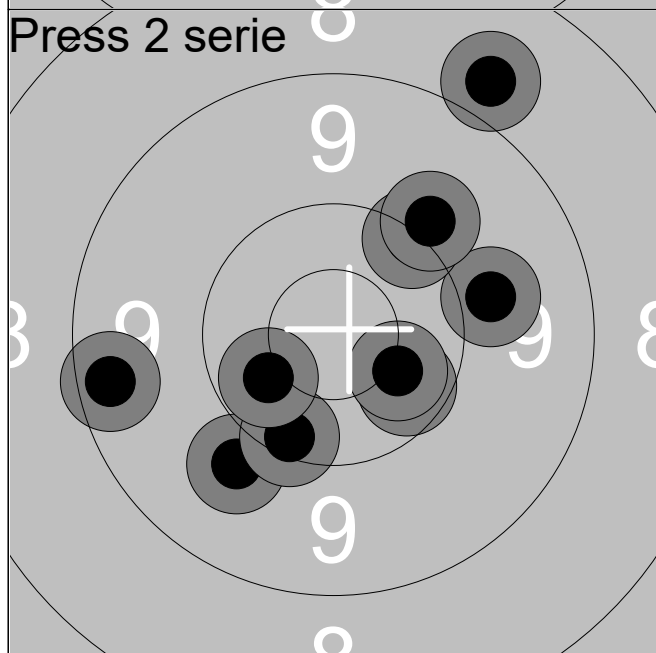

26.0s	8.9	↗
56.0s	9.9	↘
2:00m	10.2	↓
3:05m	10.4x	↘
4:09m	9.9	→
18.8s	10.2	↗
1:19m	10.0	↗
1:59m	10.5x	↘
2:36m	9.4	←
3:47m	10.4x	↘

Serie 95 (3x)

Total 190 (5x)

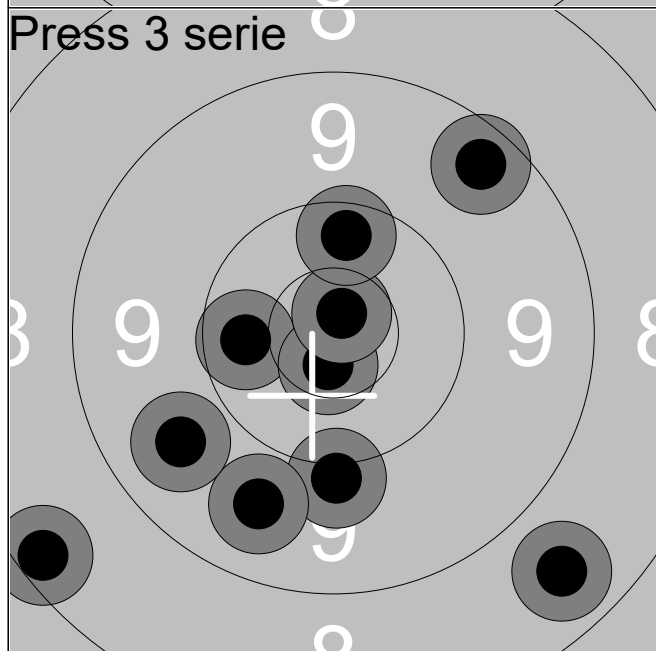

18.2s	10.4x	←
1:20m	9.4	↗
2:25m	10.7x	↓
3:29m	8.6	↘
4:07m	10.0	↓
21.8s	10.8x	↗
1:27m	9.7	↘
2:01m	10.3	↑
3:15m	9.7	←
4:18m	8.3	↘

Serie 93 (3x)

Total 283 (8x)

Lag	Skive	Pål Hembre		
2	4	Grovpistol Press	Bærum PK	A
25.06.2019	NM bane 2019	NM Pistol 2019		
Press 1 serie 	16.5s	10.0	↗	
	55.8s	10.1	↘	
	1:28m	10.8x	↖	
	1:55m	9.6	↘	
	2:59m	9.1	↘	
	15.2s	10.7x	↘	
	41.8s	10.0	←	
	1:14m	10.4x	↘	
	2:10m	9.5	↘	
	3:13m	10.2	↘	
	Serie	97 (3x)		
Total	97 (3x)			
Press 2 serie 	16.7s	8.9	→	
	42.6s	10.0	→	
	1:09m	10.5x	↗	
	1:35m	10.1	↘	
	2:34m	9.7	←	
	10.6s	9.1	↗	
	33.1s	10.6x	↗	
	55.3s	9.5	↘	
	1:22m	9.9	↑	
	1:50m	9.5	→	
	Serie	93 (2x)		
Total	190 (5x)			
Press 3 serie 	40.5s	10.8x	→	
	1:06m	10.1	↑	
	1:35m	10.0	←	
	1:59m	9.9	↘	
	2:51m	9.6	↘	
	14.1s	10.0	→	
	43.4s	10.0	↖	
	1:10m	10.6x	←	
	1:35m	10.6x	↑	
	2:28m	8.9	←	
	Serie	96 (3x)		
Total	286 (8x)			

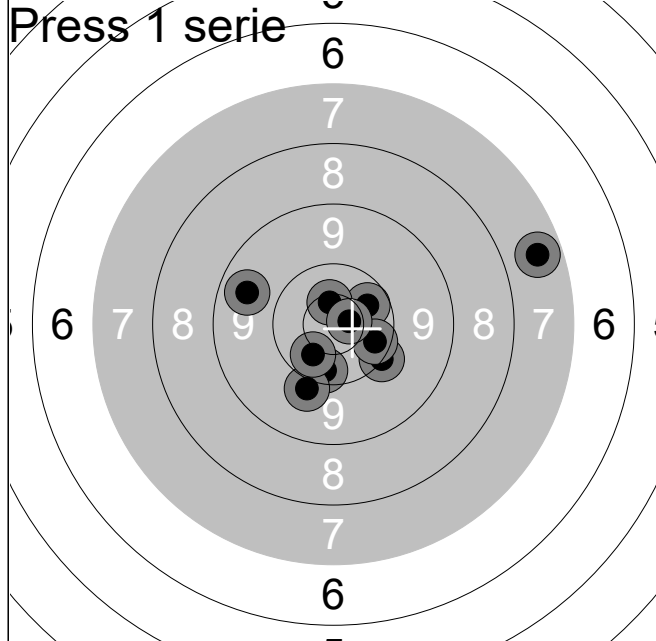

25.5s	7.6	→
54.3s	10.3	↓
1:33m	10.0	↓
2:11m	9.6	←
2:53m	10.4x	↓
1:33m	10.4x	→
2:05m	10.6x	↑
2:37m	10.1	↓
3:09m	10.3	→
3:40m	10.7x	→

Serie	96 (4x)
-------	----------

Total	96 (4x)
-------	----------

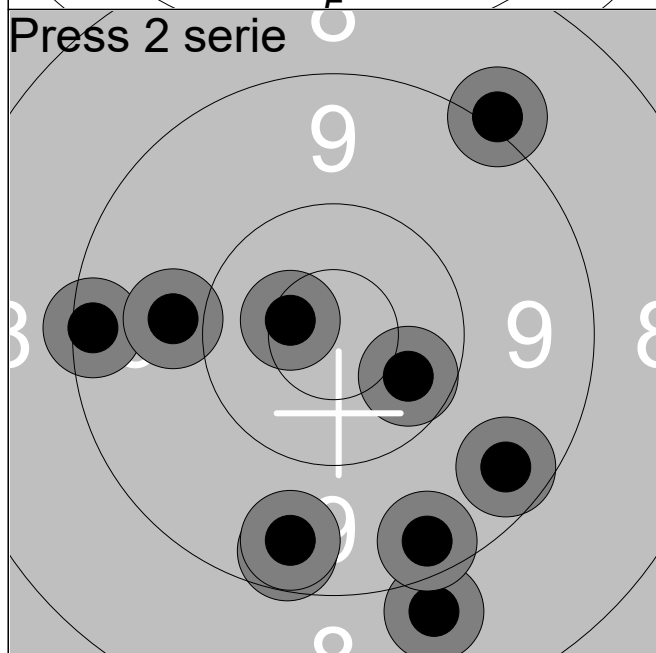

1:34m	9.3	←
2:02m	9.9	←
2:33m	9.4	↓
3:37m	8.9	↓
4:11m	9.5	↓
19.1s	10.4x	→
52.9s	9.1	↗
1:28m	10.7x	←
1:58m	9.5	↓
2:34m	9.4	↓

Serie	91 (2x)
-------	----------

Total	187 (6x)
-------	-----------

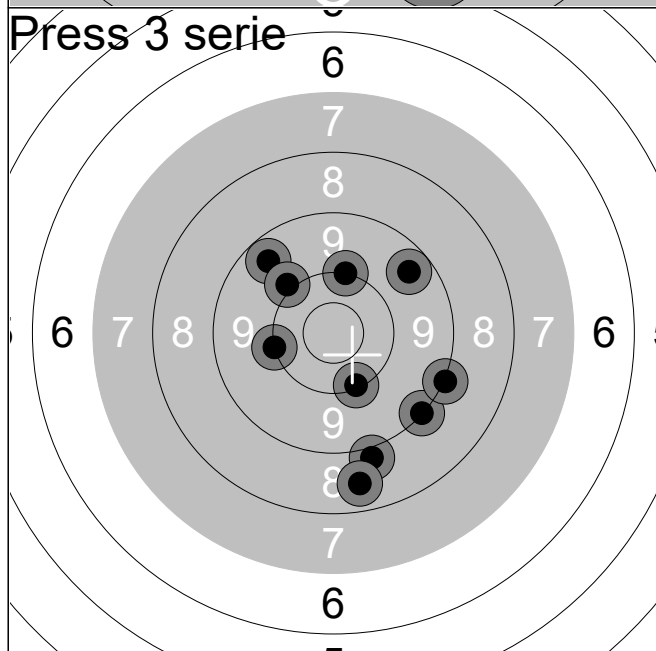

59.6s	9.0	↓
1:28m	9.5	↗
2:01m	10.1	↓
2:36m	9.2	↓
3:53m	9.5	↗
20.2s	9.1	→
59.4s	10.1	↑
2:10m	10.1	←
2:45m	10.0	↗
3:20m	8.6	↓

Serie	93 (0x)
-------	----------

Total	280 (6x)
-------	-----------

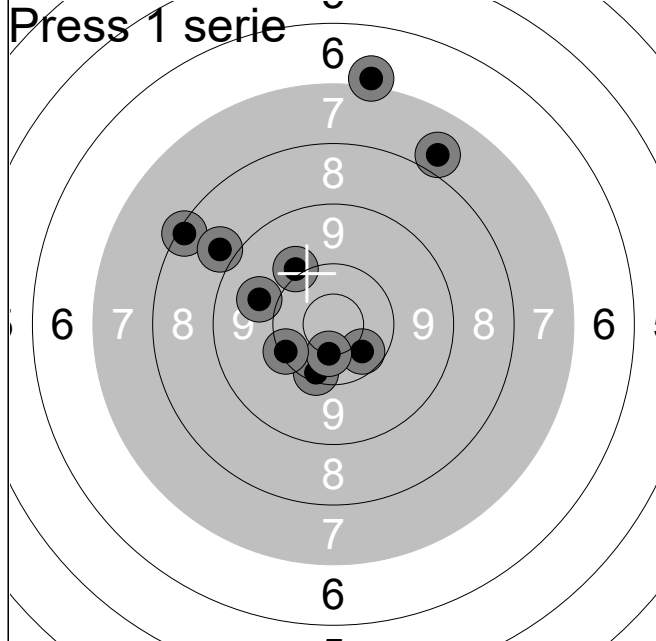

13.3s	8.2	↖
42.4s	7.8	↗
1:08m	8.9	↖
1:36m	9.8	↖
2:05m	10.4x	↘
17.3s	7.0	↑
38.8s	10.2	↘
1:05m	10.0	↗
1:47m	10.5x	↘
2:28m	10.2	↖

Serie	89 (2x)
Total	89 (2x)

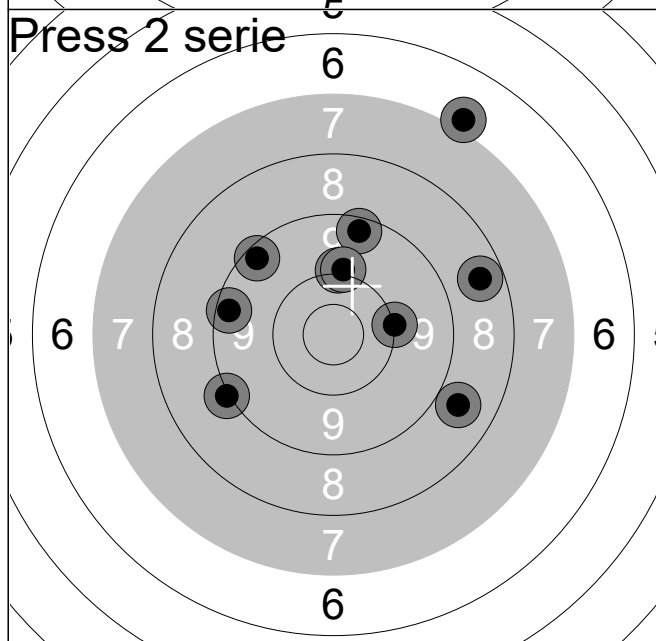

13.7s	9.3	↖
42.1s	10.0	↑
1:23m	7.0	↗
1:49m	9.4	↑
2:16m	10.0	↑
19.7s	9.4	↖
51.4s	10.1	→
1:24m	8.5	→
1:55m	9.1	↖
2:21m	8.8	↘

Serie	89 (0x)
Total	178 (2x)

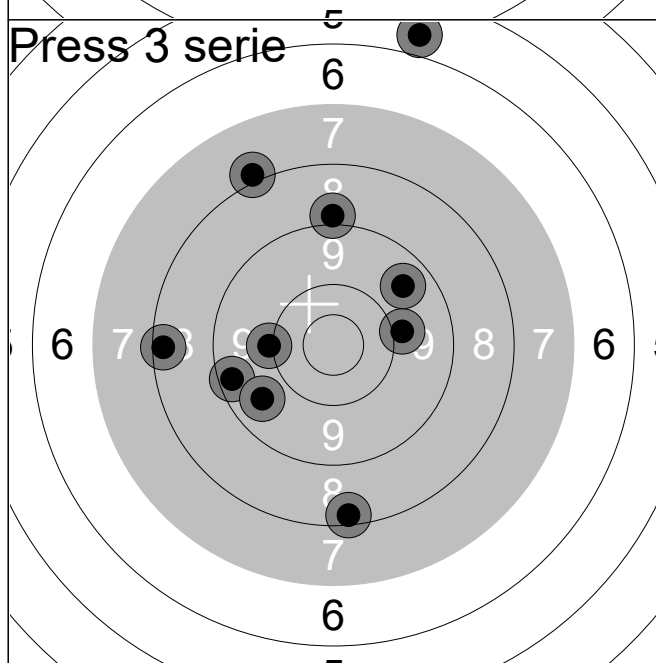

13.1s	8.3	←
35.1s	10.0	←
59.2s	5.8	↑
1:17m	9.0	↑
1:38m	8.3	↘
12.0s	8.0	↗
32.7s	9.4	↖
55.0s	9.7	↖
1:24m	10.0	→
1:54m	9.6	↗

Serie	85 (0x)
Total	263 (2x)

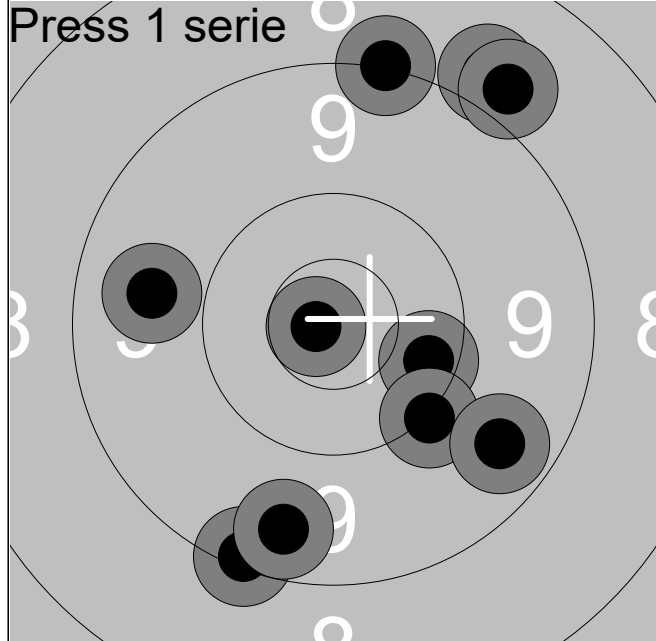

15.5s	9.2	↓
41.9s	10.8x	←
1:08m	8.9	↗
1:35m	9.5	↓
2:04m	10.3	→
13.6s	8.9	↗
1:02m	9.1	↑
1:50m	10.1	↓
2:13m	9.6	↓
2:35m	9.7	←

Serie	91 (1x)
-------	----------

Total	91 (1x)
-------	----------

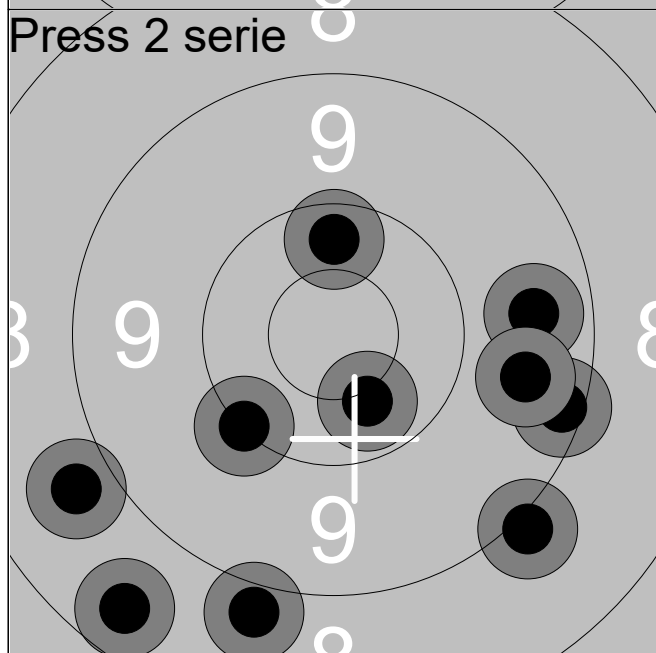

12.9s	8.9	↓
39.8s	10.5x	↓
1:29m	10.1	↙
1:44m	8.8	←
2:07m	9.0	↓
37.6s	10.3	↑
54.3s	9.3	→
1:15m	9.6	→
2:26m	9.6	→
2:47m	8.5	↙

Serie	90 (1x)
-------	----------

Total	181 (2x)
-------	-----------

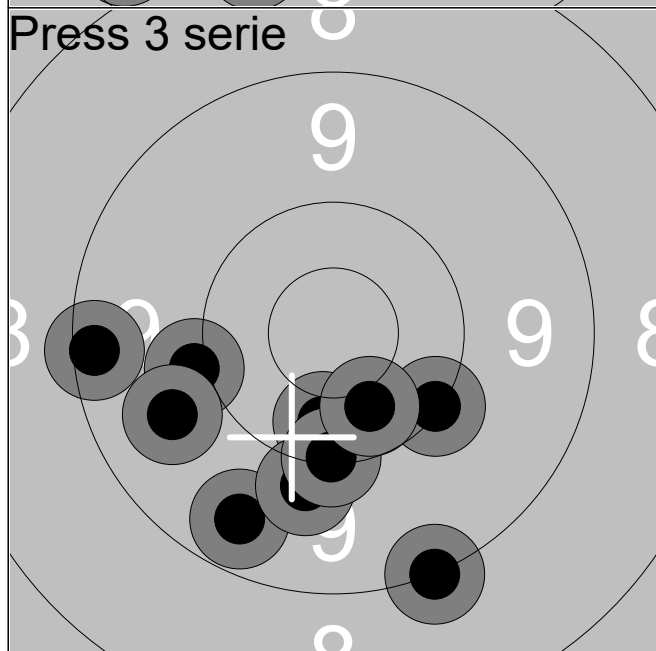

15.3s	10.0	←
38.1s	9.3	←
1:07m	10.4x	↓
1:40m	9.5	↓
2:04m	10.0	↓
19.3s	9.8	↙
1:05m	10.2	↓
1:53m	10.1	↘
2:17m	9.1	↓
2:42m	10.4x	↘

Serie	96 (2x)
-------	----------

Total	277 (4x)
-------	-----------

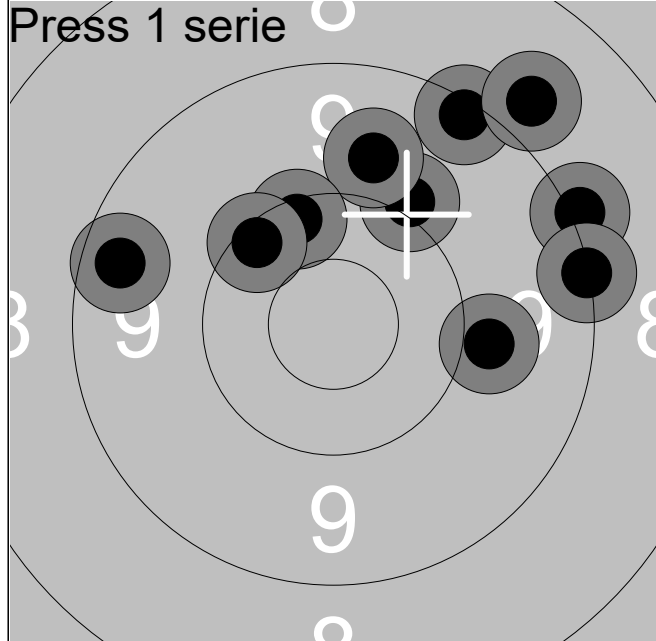

13.5s	10.0	↗
35.3s	9.1	→
1:08m	9.8	↑
1:31m	9.9	→
2:07m	10.2	↑
12.5s	9.4	←
34.3s	9.3	↗
1:17m	10.2	↖
1:40m	8.9	↗
2:12m	9.2	→

Serie	92 (0x)
--------------	-----------------

Total	92 (0x)
--------------	-----------------

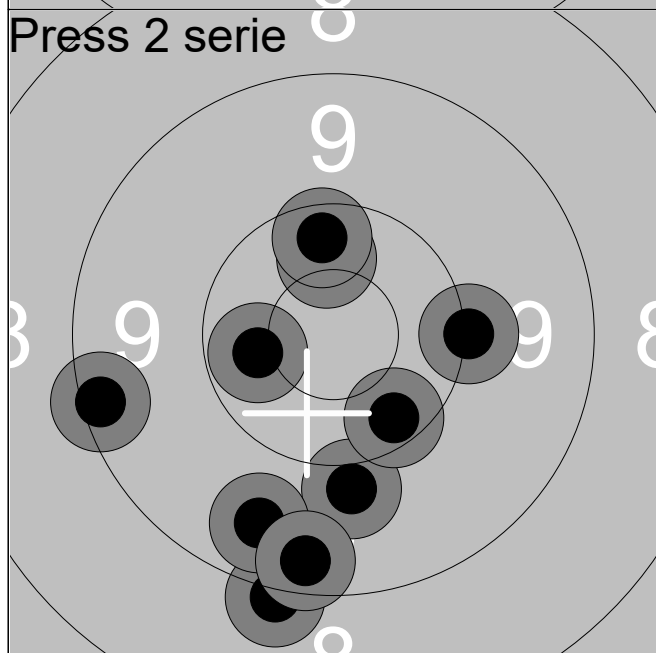

17.1s	10.0	↓
1:01m	10.5x	↑
1:44m	10.3	↑
2:02m	10.4x	←
2:21m	9.1	↓
14.9s	9.3	←
36.6s	10.1	→
1:03m	10.3	↓
1:28m	9.6	↓
2:07m	9.4	↓

Serie	96 (2x)
--------------	-----------------

Total	188 (2x)
--------------	------------------

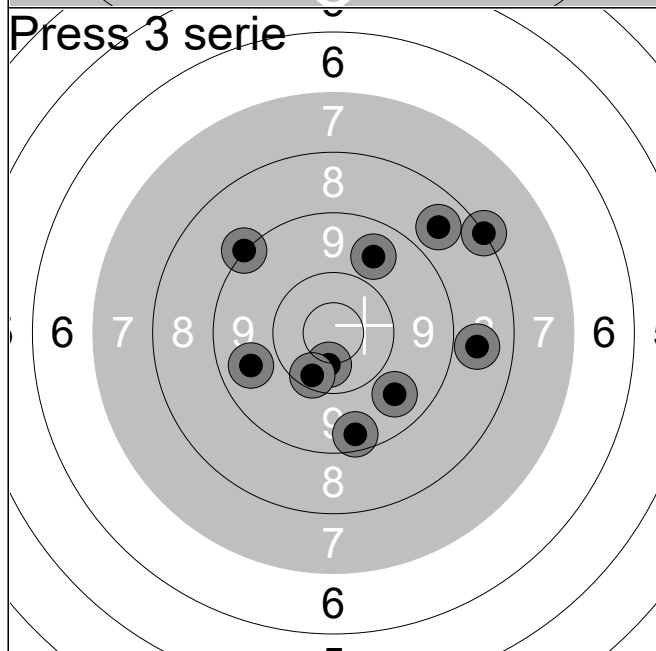

19.7s	9.7	↘
42.9s	8.1	↗
1:15m	9.4	↓
1:51m	8.7	→
2:24m	10.5x	↓
39.4s	9.1	↖
1:11m	9.7	↗
1:32m	10.3	↓
2:20m	9.7	←
3:24m	8.7	↗

Serie	89 (1x)
--------------	-----------------

Total	277 (3x)
--------------	------------------

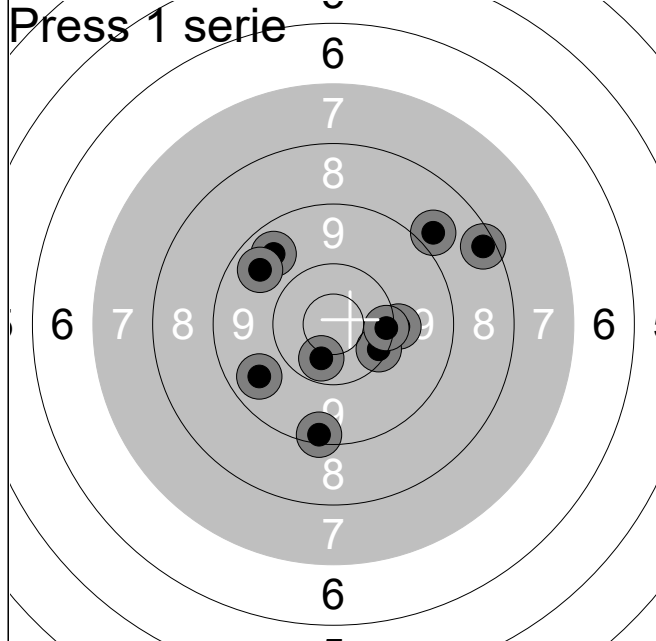

13.3s	9.6	↗
53.4s	8.3	↗
1:30m	8.9	↗
2:05m	10.0	→
2:35m	10.4x	↓
21.3s	10.2	↘
51.4s	9.6	↗
1:21m	10.2	→
1:55m	9.6	↖
2:35m	9.3	↓
Serie	92 (1x)	
Total	92 (1x)	

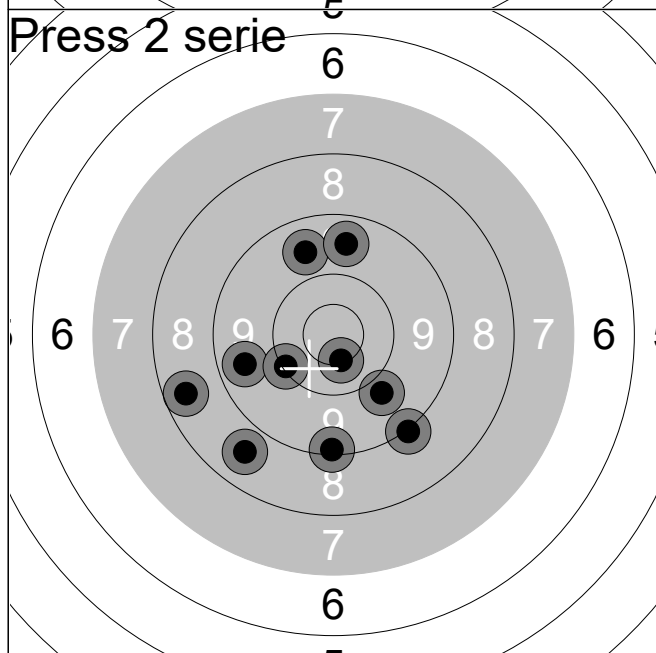

21.2s	9.1	↘
54.0s	9.6	←
1:22m	8.7	↘
2:09m	9.7	↑
2:37m	10.1	↖
14.0s	9.6	↑
45.5s	8.5	←
1:14m	9.9	↘
2:09m	10.6x	↓
2:38m	9.2	↓
Serie	90 (1x)	
Total	182 (2x)	

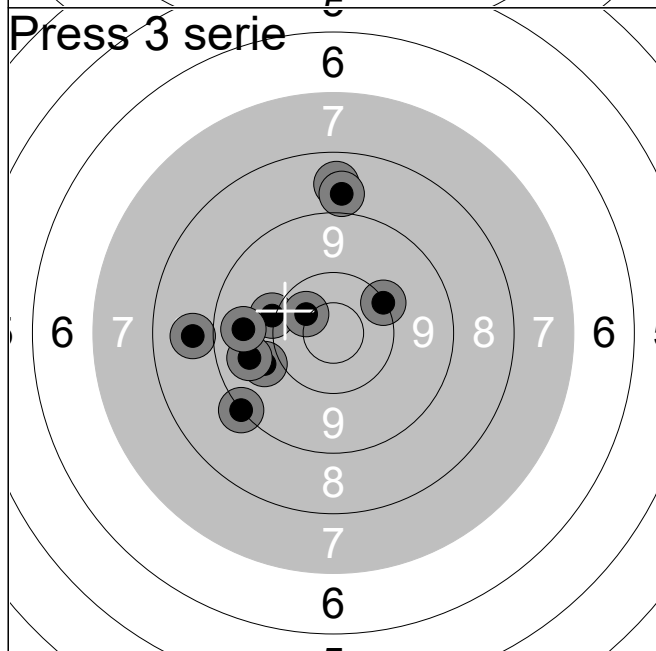

19.5s	10.1	↗
45.5s	10.1	←
1:17m	9.1	↘
1:52m	8.7	↑
2:21m	9.9	↖
52.7s	8.8	←
1:22m	8.8	↑
1:54m	10.5x	↖
2:27m	9.7	←
3:01m	9.6	←
Serie	90 (1x)	
Total	272 (3x)	

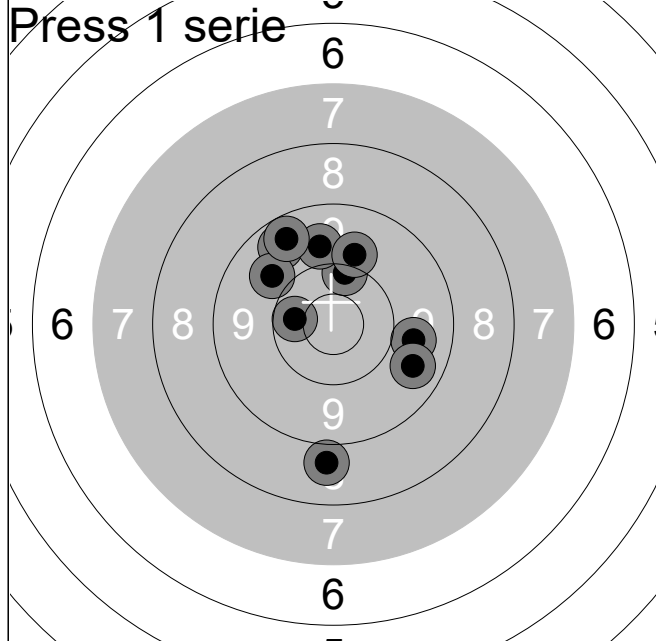

13.3s	9.6	↗
29.8s	10.2	↑
1:04m	9.8	↑
1:34m	10.4x	←
2:03m	8.8	↓
17.0s	9.8	→
40.6s	9.8	↗
1:01m	9.9	↑
1:17m	9.6	↘
1:42m	9.5	↗
Serie		91 (1x)
Total		91 (1x)

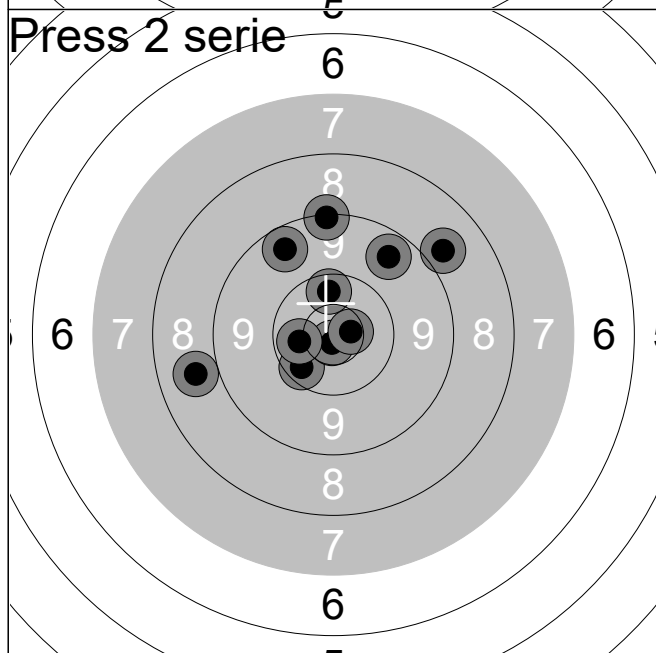

23.6s	10.3	↙
51.3s	9.2	↑
1:15m	9.6	↗
1:46m	8.8	←
2:12m	10.8x	↓
13.8s	10.3	↑
39.0s	10.7x	→
1:07m	10.5x	←
1:40m	8.8	↗
2:07m	9.5	↖
Serie		93 (3x)
Total		184 (4x)

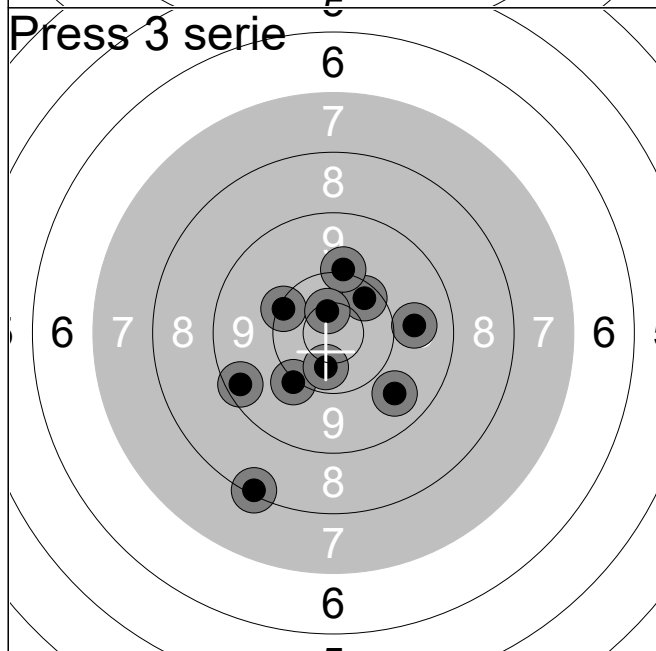

17.8s	9.7	↘
44.6s	10.3	↗
1:12m	10.1	↑
2:25m	10.2	←
2:57m	10.1	↙
24.8s	10.6x	↑
1:01m	9.4	←
1:36m	10.5x	↓
2:08m	9.8	→
2:46m	8.2	↙
Serie		95 (2x)
Total		279 (6x)

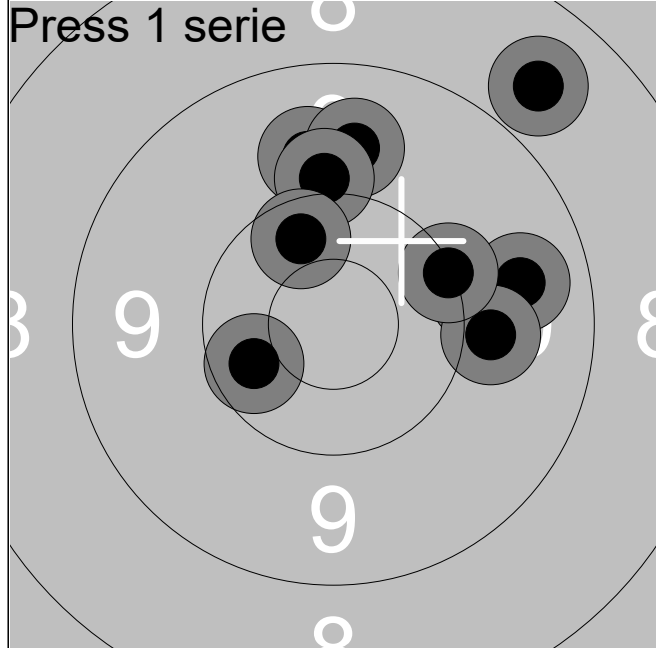

19.9s	8.7	↗
54.9s	10.0	→
1:38m	9.7	→
2:20m	9.8	↑
2:58m	9.8	↑
18.0s	10.0	↑
54.0s	9.9	→
1:27m	10.4x	↖
2:00m	10.4	↑
3:11m	10.1	↗

Serie	94 (1x)
Total	94 (1x)

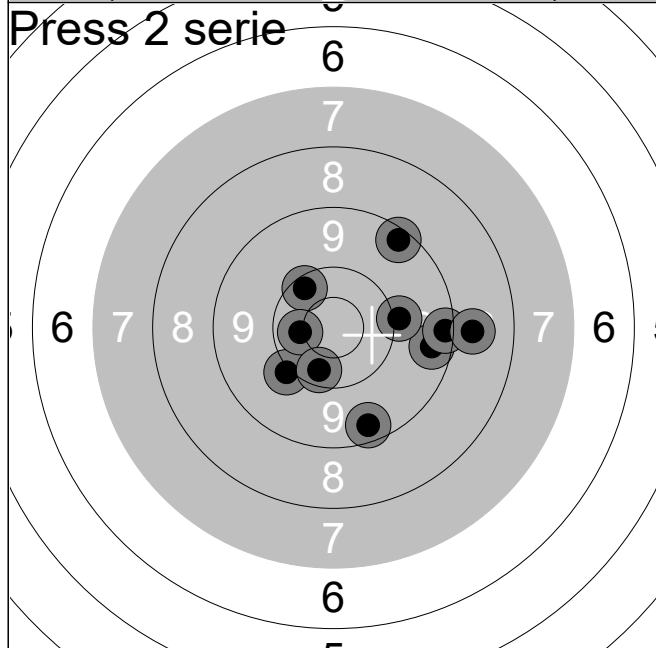

17.6s	9.3	↗
52.1s	9.5	→
1:31m	10.3	↗
2:05m	10.0	↖
2:43m	10.5x	←
23.0s	9.3	→
59.9s	10.3	↓
1:35m	9.4	↓
2:10m	10.0	→
3:17m	8.8	→

Serie	94 (1x)
Total	188 (2x)

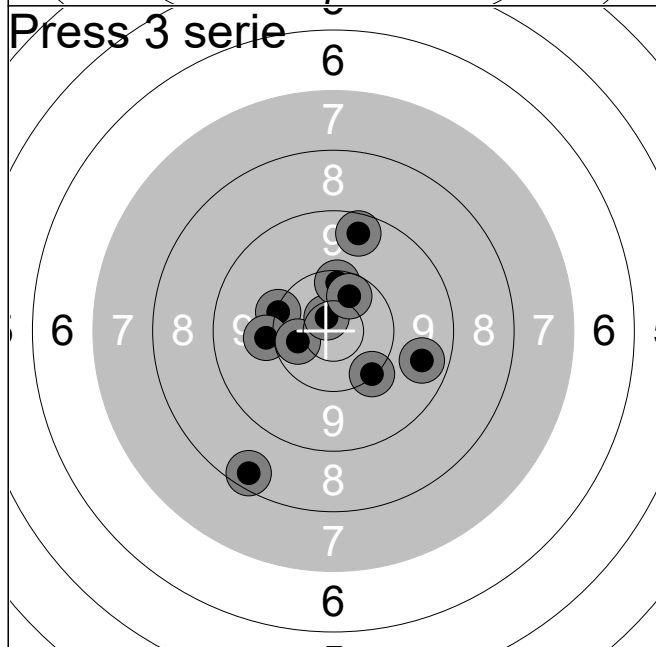

49.2s	10.1	↖
1:25m	10.0	↖
2:32m	10.4x	↖
3:32m	10.7x	↗
4:04m	10.3	↑
50.2s	10.4x	↗
1:52m	9.6	→
2:59m	8.4	↖
3:33m	10.1	↘
4:32m	9.5	↑

Serie	96 (3x)
Total	284 (5x)

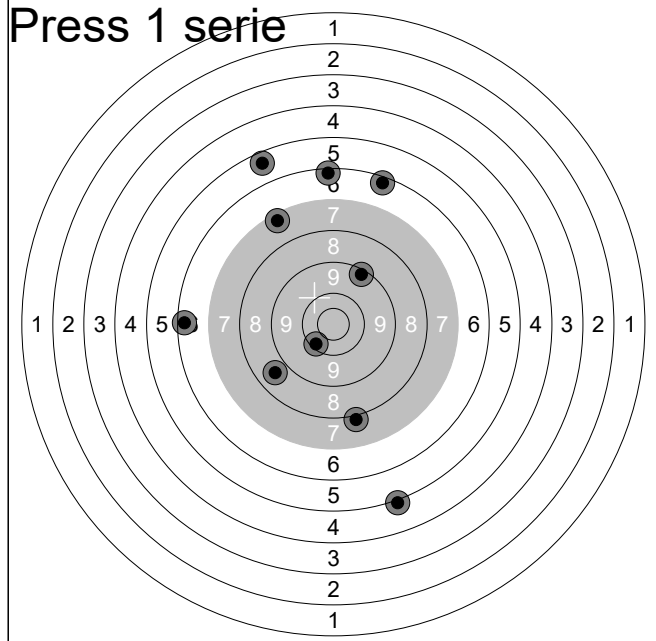

1	18.0s	9.3	↗
2	38.9s	6.3	↗
3	1:03m	7.4	↖
4	1:25m	8.7	↖
5	1:48m	8.0	↓
6	9.92s	10.2	↙
7	30.3s	6.4	←
8	50.5s	6.3	↑
9	1:24m	5.5	↗
10	1:52m	5.1	↓
Serie			70 (0x)
Total			70 (0x)

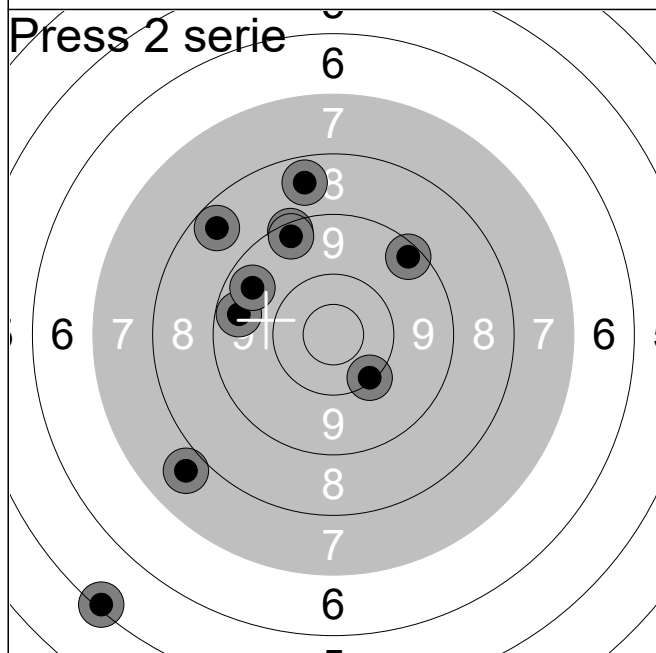

1	12.4s	5.2	↙
2	31.3s	9.3	↗
3	50.5s	7.8	↙
4	1:16m	10.2	↘
5	1:38m	9.3	↗
6	14.5s	8.5	↗
7	36.2s	8.6	↑
8	59.8s	9.5	←
9	1:38m	9.6	↖
10	2:31m	9.4	↗
Serie			83 (0x)
Total			153 (0x)

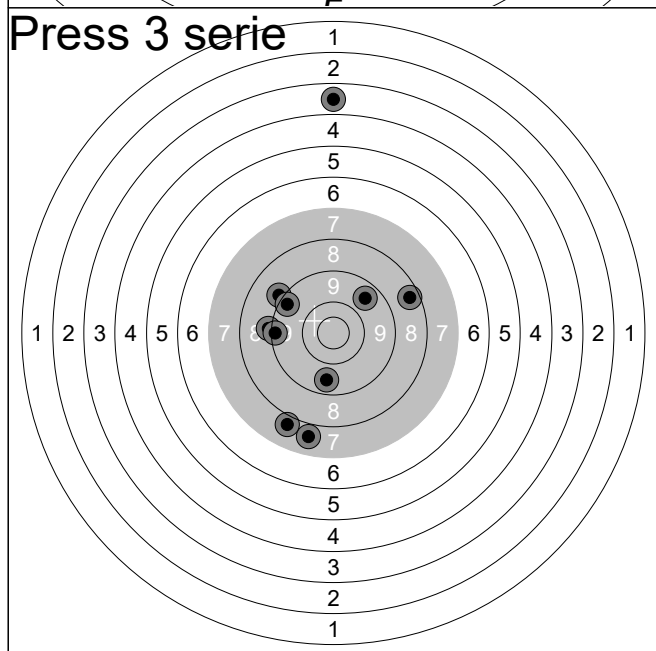

1	9.86s	9.0	←
2	36.0s	3.6	↑
3	1:06m	8.4	↗
4	1:30m	7.7	↓
5	2:07m	9.0	↖
6	12.9s	9.4	↖
7	41.9s	9.3	←
8	1:05m	7.9	↙
9	1:27m	9.6	↗
10	2:22m	9.6	↓
Serie			79 (0x)
Total			232 (0x)

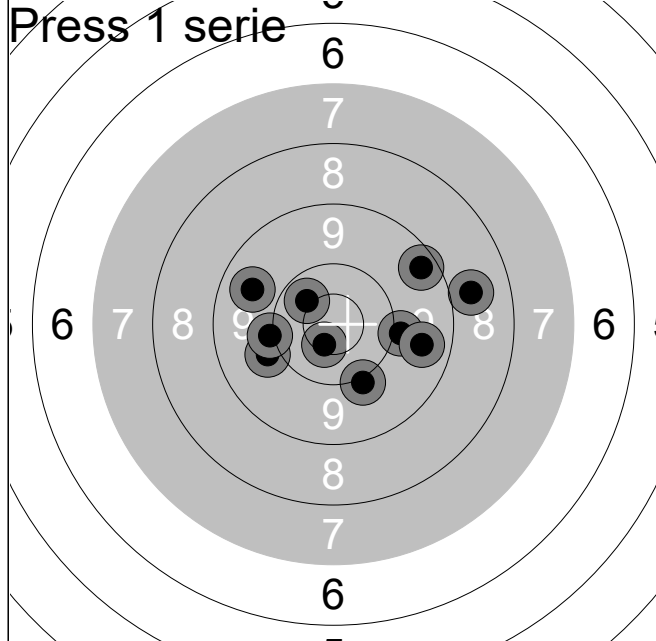

20.8s	9.9	↙
49.5s	9.4	↗
1:18m	10.0	→
1:47m	9.7	↖
2:20m	10.0	←
20.9s	8.8	→
52.0s	10.6x	↓
1:17m	10.5x	↗
1:46m	9.6	→
2:19m	10.0	↓
Serie	94 (2x)	
Total	94 (2x)	

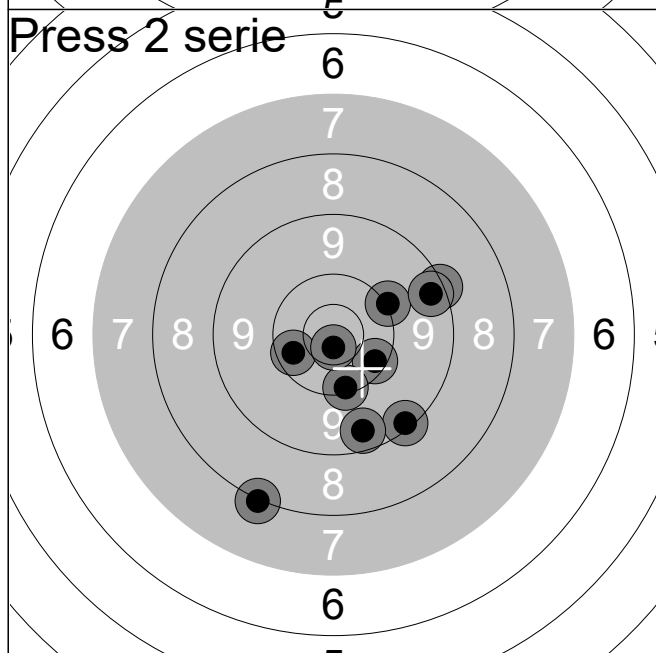

21.3s	8.1	↓
46.0s	10.1	↗
1:12m	9.2	↗
1:45m	10.3	↘
2:18m	10.3	↖
19.2s	9.2	↓
45.7s	10.2	↓
1:12m	9.4	↗
1:40m	10.8x	↓
2:10m	9.5	↓
Serie	94 (1x)	
Total	188 (3x)	

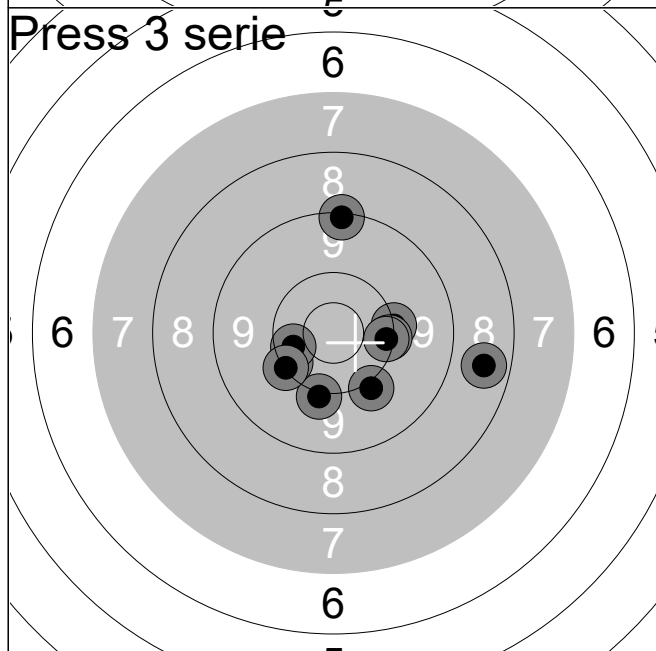

19.5s	10.0	↓
44.3s	10.1	→
1:10m	10.2	↖
1:34m	10.0	↓
1:58m	10.4	↖
16.4s	9.2	↑
45.3s	10.2	→
1:14m	8.6	→
1:47m	10.2	→
2:20m	10.1	↖
Serie	97 (0x)	
Total	285 (3x)	

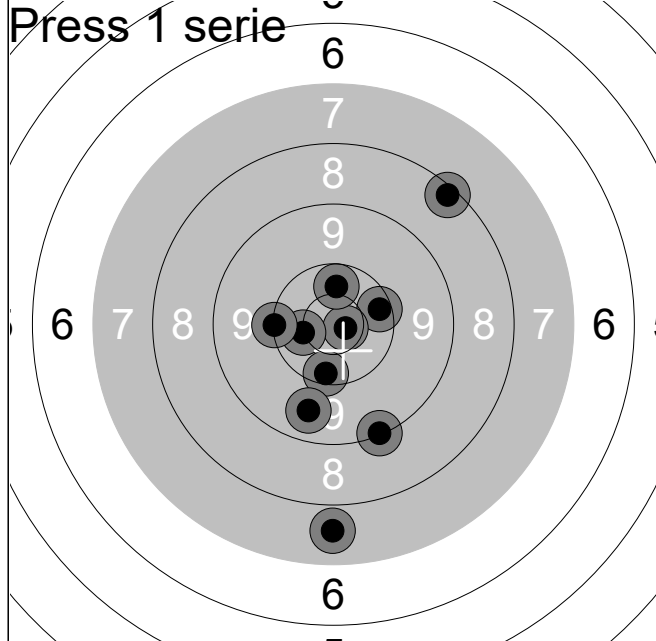

13.6s	8.3	↗
47.3s	10.3	↓
1:21m	9.6	↓
1:56m	10.3	→
2:31m	9.2	↓
17.2s	10.8x	→
47.7s	7.7	↓
1:17m	10.4x	↑
1:51m	10.5x	←
2:59m	10.1	←
Serie		93 (3x)
Total		93 (3x)

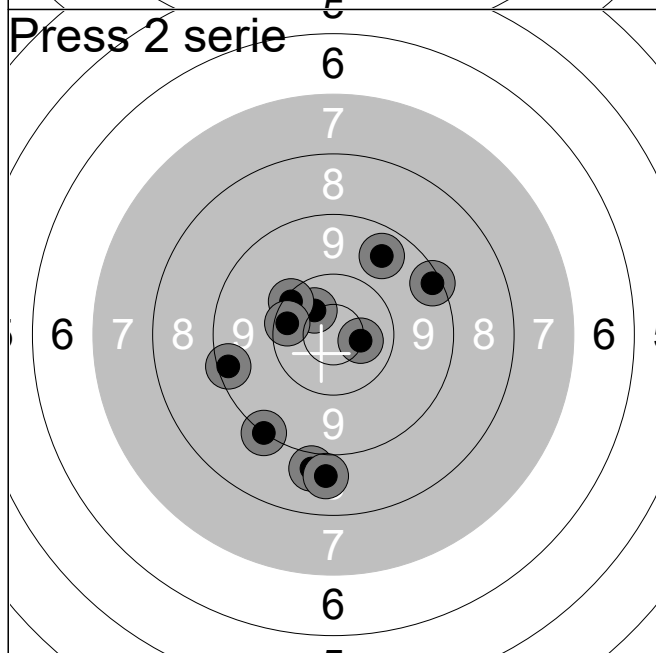

17.5s	9.3	↗
48.7s	9.3	←
1:21m	10.5x	↗
1:59m	8.9	↓
2:33m	9.1	↓
19.1s	9.6	↗
50.1s	10.2	↗
2:00m	10.3	←
2:29m	8.8	↓
2:59m	10.6x	→
Serie		92 (2x)
Total		185 (5x)

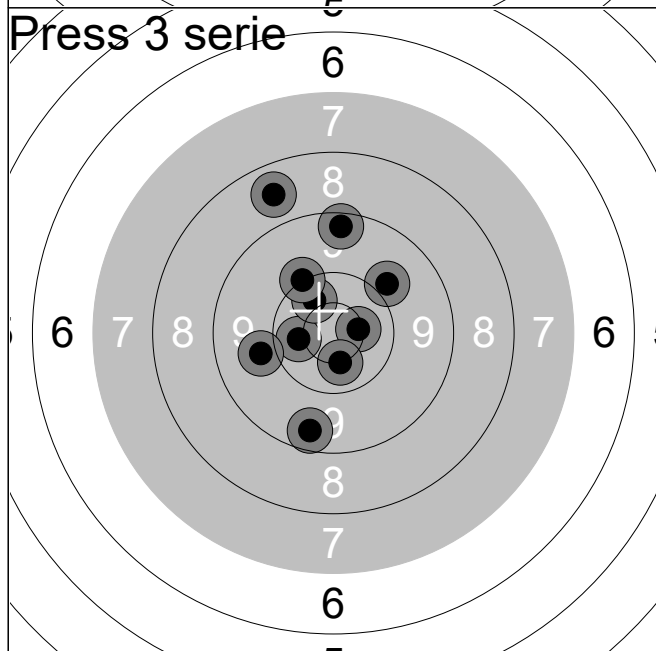

16.5s	10.6x	→
47.8s	9.9	↗
1:17m	10.5x	←
1:49m	8.6	↗
2:19m	9.4	↑
18.2s	10.4x	↗
48.0s	9.9	←
1:19m	10.1	↗
1:53m	9.5	↓
2:25m	10.5x	↓
Serie		94 (4x)
Total		279 (9x)

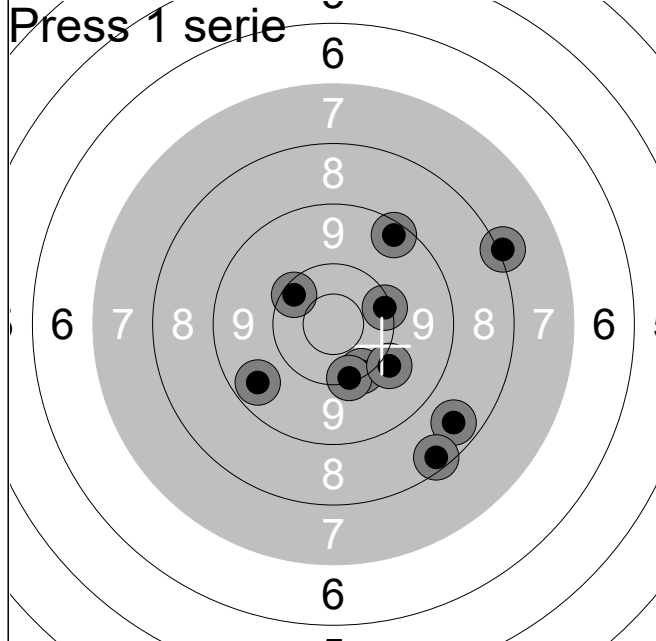

12.3s	10.3	↗
43.6s	8.5	↘
1:10m	10.2	↘
1:43m	8.1	↗
2:18m	9.6	↖
17.1s	8.3	↘
45.9s	10.2	↘
1:19m	9.3	↗
1:45m	10.0	↘
2:13m	10.2	→

Serie	92 (0x)
Total	92 (0x)

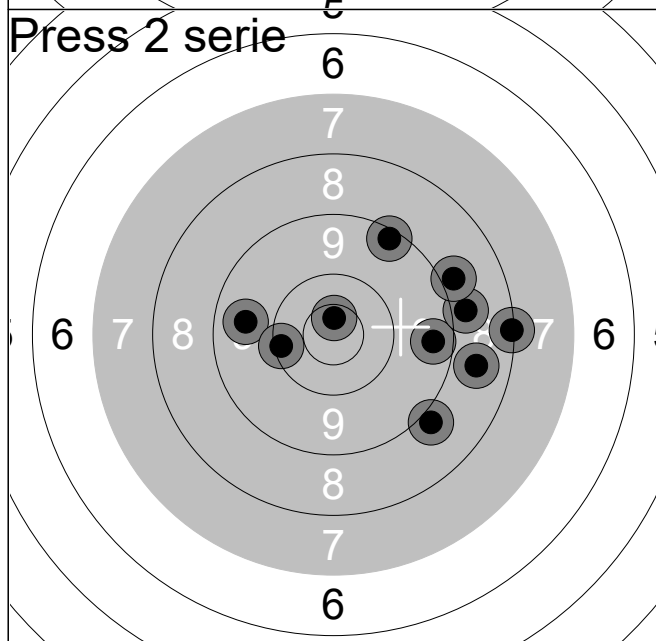

12.4s	9.5	→
41.4s	8.9	→
1:10m	9.7	←
1:37m	10.2	←
2:02m	8.2	→
13.8s	8.7	→
37.4s	10.7x	↑
1:02m	9.3	↗
1:31m	9.0	↘
1:52m	8.9	↗

Serie	88 (1x)
Total	180 (1x)

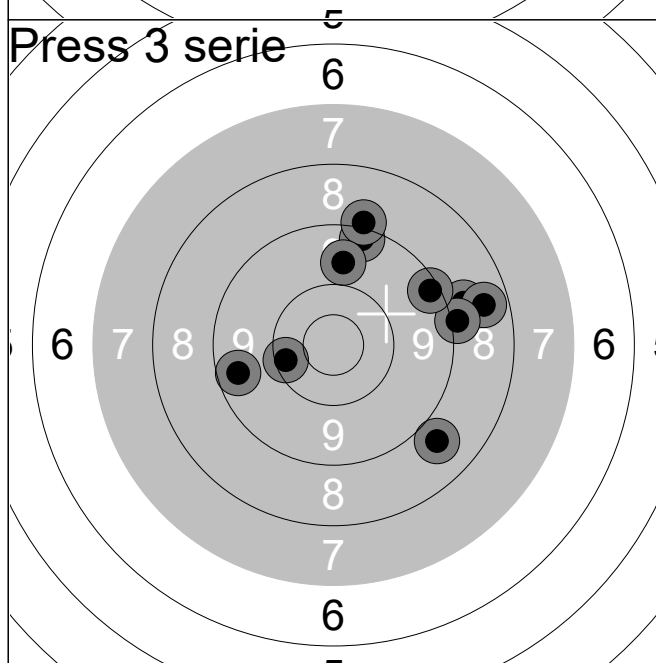

12.1s	8.9	→
46.8s	8.8	↘
1:06m	8.5	→
1:26m	9.3	↑
2:22m	9.0	↑
14.4s	9.0	→
36.8s	9.5	←
1:02m	10.2	←
1:26m	9.8	↑
2:17m	9.3	↗

Serie	88 (0x)
Total	268 (1x)

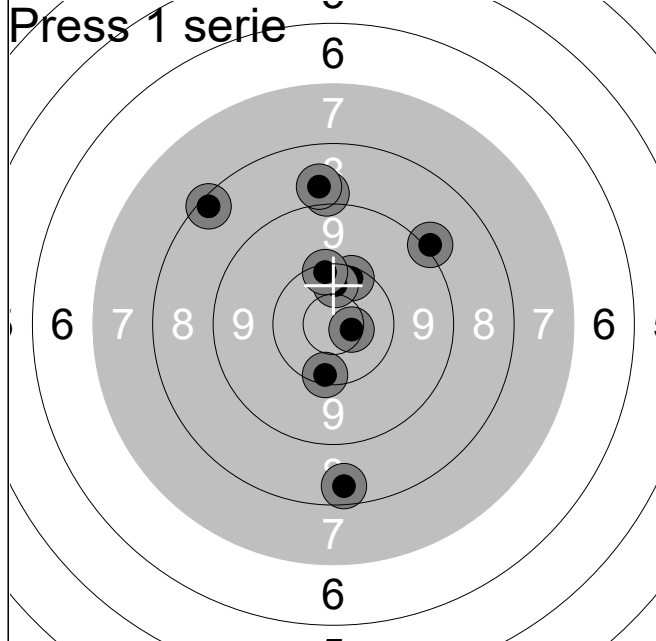

21.9s	10.2	↓
53.8s	9.0	↑
1:28m	8.4	↓
2:05m	9.1	↗
2:46m	10.3	↗
25.1s	10.4x	↑
56.6s	8.3	↖
1:34m	10.2	↑
2:05m	8.8	↑
2:46m	10.7x	→
Serie		92 (2x)
Total		92 (2x)

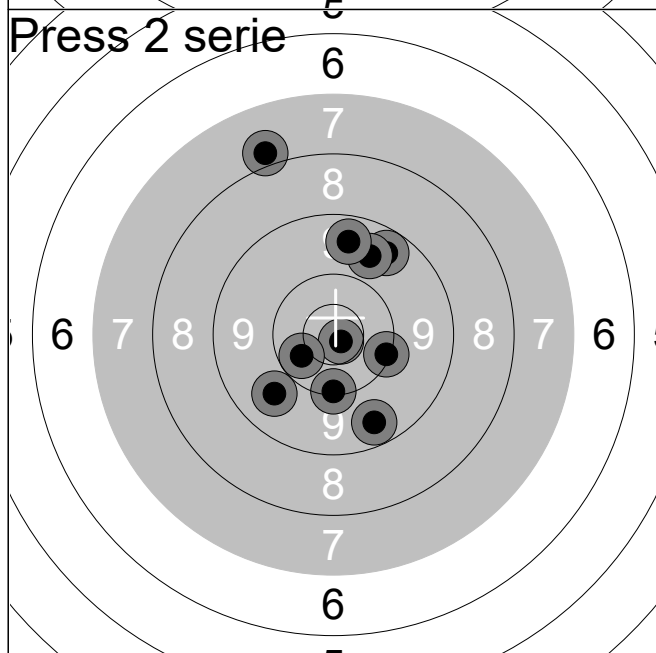

46.1s	10.8x	↘
1:14m	9.5	↗
1:44m	7.9	↑
2:24m	9.7	↗
3:03m	10.2	↓
50.4s	10.2	→
1:14m	9.7	↘
1:42m	10.4x	↖
2:10m	9.6	↑
2:39m	9.5	↓
Serie		92 (2x)
Total		184 (4x)

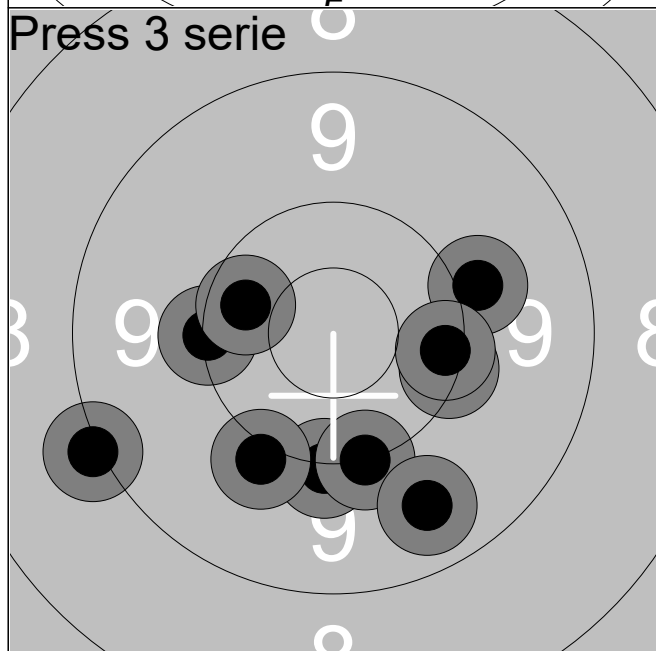

20.6s	10.1	←
50.0s	9.1	↖
1:23m	10.1	↓
1:53m	10.1	↓
2:24m	10.4	↖
22.2s	10.0	↘
53.2s	10.0	→
1:21m	9.6	↓
1:52m	10.2	→
2:23m	10.2	→
Serie		98 (0x)
Total		282 (4x)

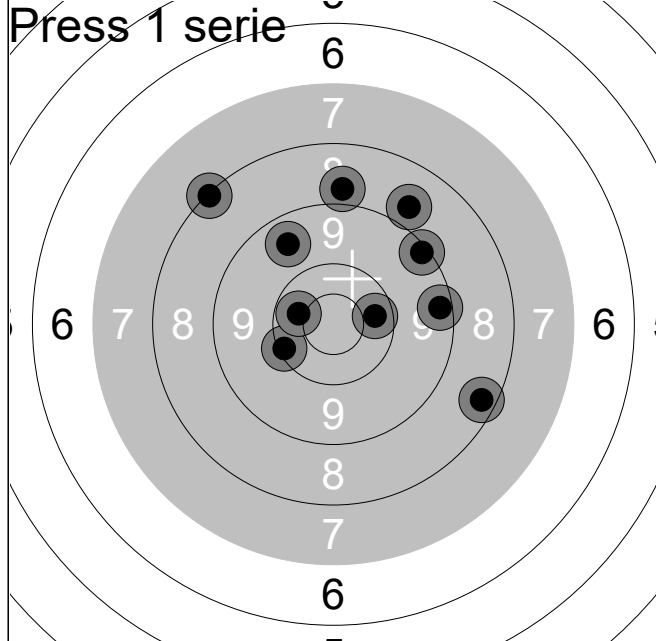

15.0s	10.2	↙
37.5s	8.2	↗
1:09m	9.2	↗
1:41m	10.4	→
2:41m	9.4	→
10.7s	8.9	↑
43.3s	9.6	↗
1:22m	10.4x	↙
1:57m	8.8	↗
2:36m	8.4	↘
Serie		89 (1x)
Total		89 (1x)

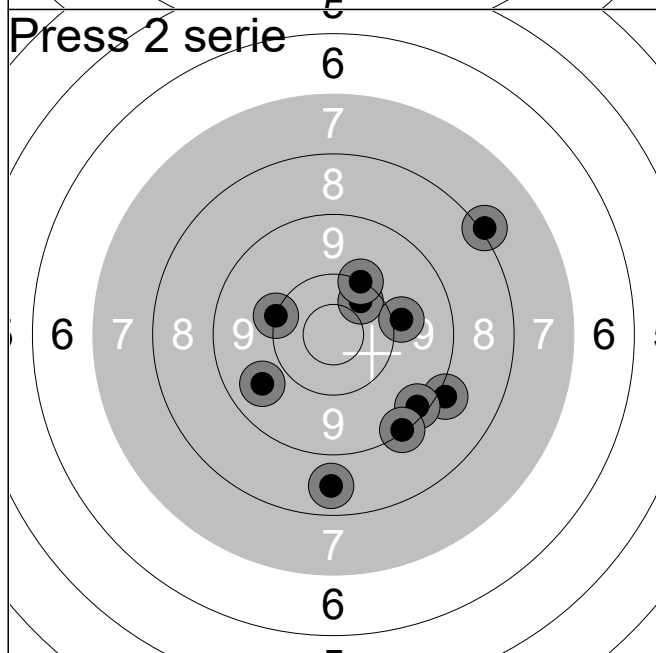

36.9s	10.4	↗
1:04m	9.0	↘
1:36m	9.7	↙
2:09m	10.0	→
2:42m	9.3	↘
15.1s	10.1	↙
40.4s	10.1	↗
1:11m	8.6	↓
1:51m	8.1	↗
2:52m	9.2	↘
Serie		92 (0x)
Total		181 (1x)

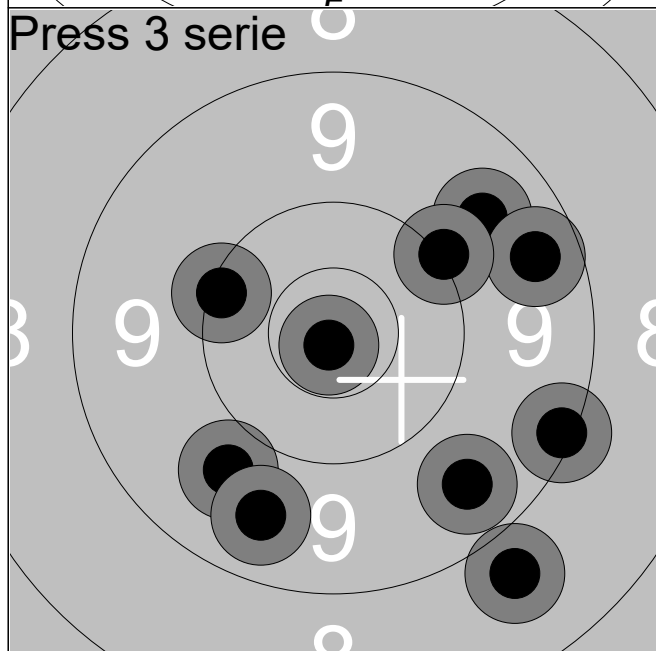

55.8s	9.7	↗
1:31m	8.8	↘
2:15m	9.5	→
3:15m	9.8	↘
3:53m	9.6	↘
18.3s	9.6	↘
48.1s	10.9x	↘
1:20m	9.2	↘
1:58m	10.2	↙
2:47m	10.1	↗
Serie		92 (1x)
Total		273 (2x)

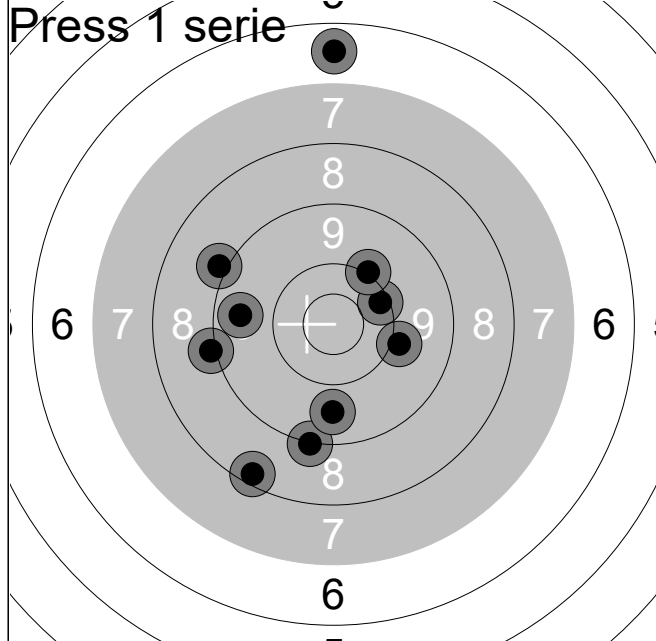

37.4s	9.6	←
1:01m	10.2	→
1:29m	9.1	↓
2:19m	9.7	↓
2:44m	9.1	←
21.7s	8.3	↓
1:15m	9.0	↖
2:05m	6.6	↑
2:29m	10.0	→
2:52m	10.1	↗
Serie		89 (0x)
Total		89 (0x)

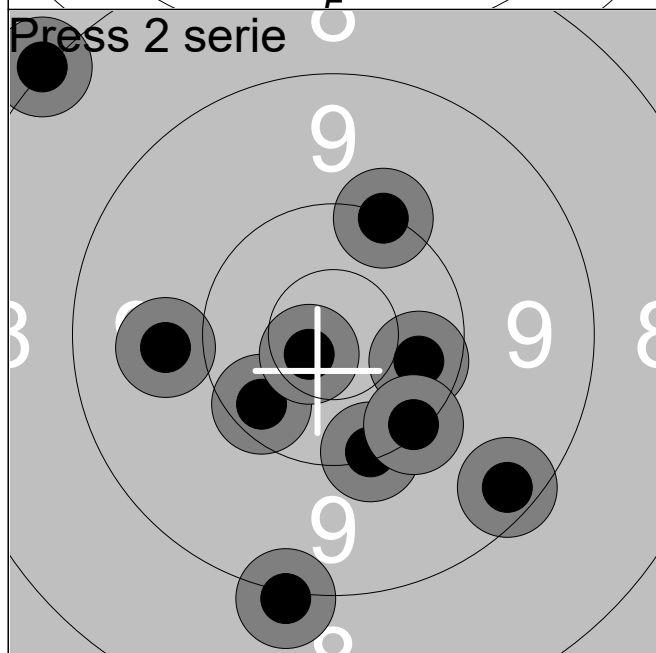

20.3s	10.1	↗
48.0s	10.3	↖
1:40m	10.4x	→
2:19m	9.1	↓
2:52m	10.2	↓
22.4s	8.1	↗
1:10m	10.7x	↖
1:46m	9.4	↓
2:22m	10.2	↓
3:03m	9.9	←
Serie		95 (2x)
Total		184 (2x)

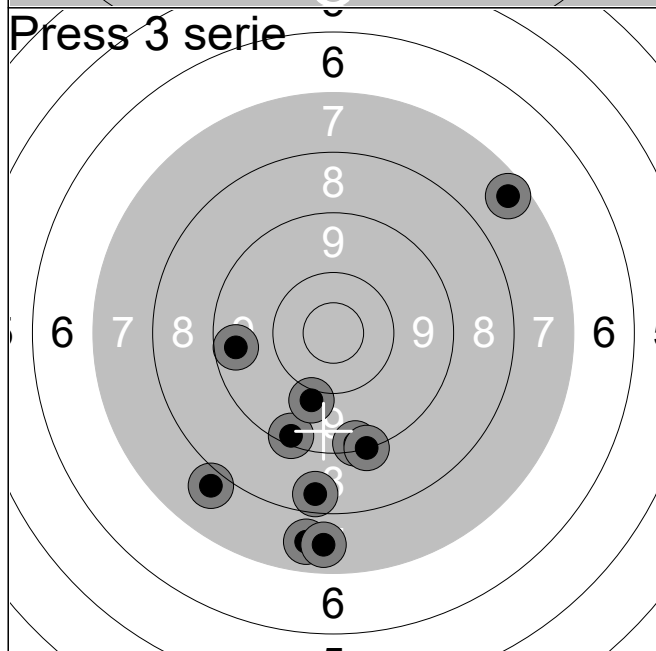

21.4s	9.3	↓
56.0s	7.9	↖
1:50m	9.3	↓
2:18m	7.5	↗
3:12m	9.1	↓
17.3s	7.6	↓
1:14m	7.6	↓
1:52m	8.5	↓
2:20m	9.5	←
2:51m	10.0	↓
Serie		82 (0x)
Total		266 (2x)

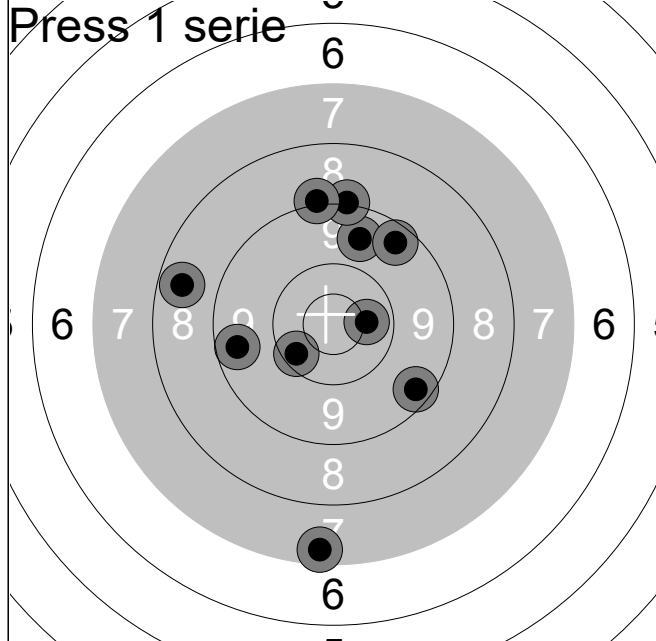

17.6s	9.5	←
45.9s	9.7	↑
1:11m	9.1	↑
1:41m	10.3	↙
2:13m	7.4	↓
22.5s	9.4	↘
50.0s	9.4	↗
1:25m	8.5	←
2:00m	9.1	↑
2:28m	10.5x	→

Serie	89 (1x)
Total	89 (1x)

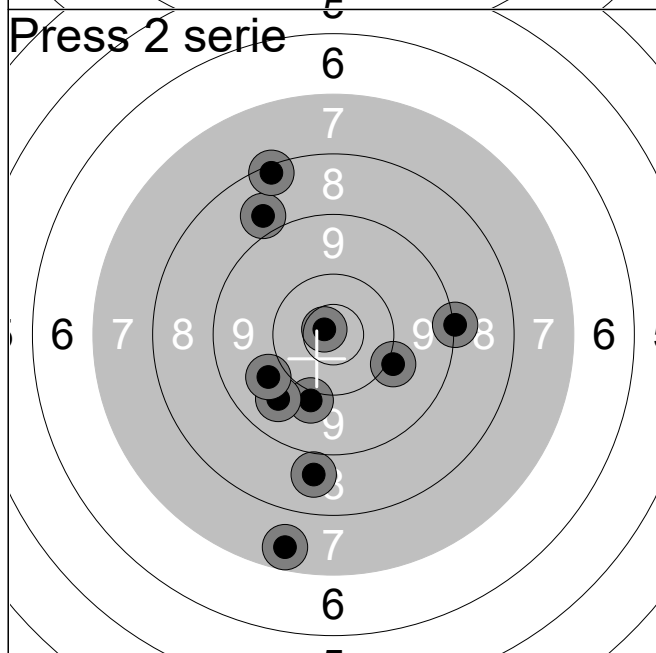

15.2s	7.5	↓
42.4s	8.8	↗
1:08m	10.8x	↙
1:41m	10.0	↓
2:14m	9.1	→
17.1s	8.8	↓
46.5s	9.7	↙
1:20m	9.9	↙
1:49m	10.0	↘
2:17m	8.3	↑

Serie	88 (1x)
Total	177 (2x)

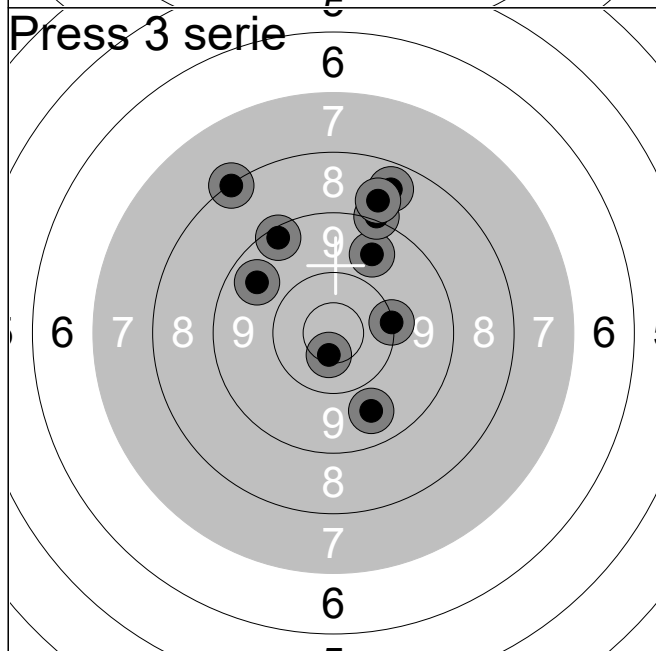

21.0s	9.7	↓
47.8s	9.7	↗
1:21m	9.6	↙
1:45m	10.6x	↓
2:11m	9.1	↑
13.8s	8.6	↗
40.7s	8.8	↗
1:09m	9.3	↗
1:42m	8.2	↗
2:09m	10.1	→

Serie	89 (1x)
Total	266 (3x)

Lag 2	Skive 20	Frank Lien		
Grovpistol Press		Ringerike Pk		A
25.06.2019		NM bane 2019		NM Pistol 2019
Press 1 serie 	13.4s	9.8	↑	
	38.9s	8.6	➔	
	1:05m	10.3	➤	
	1:35m	9.6	↑	
	2:04m	9.7	↗	
	10.4s	8.5	↓	
	34.2s	8.9	↗	
	59.6s	10.0	↗	
	1:24m	10.6x	➔	
	1:47m	9.4	➔	
Serie		90 (1x)		
Total		90 (1x)		
Press 2 serie 	14.7s	10.4x	↑	
	45.9s	10.7x	➔	
	1:15m	9.2	↓	
	2:20m	9.8	←	
	2:49m	10.5x	←	
	13.2s	10.4x	↓	
	43.1s	10.1	↑	
	1:54m	9.6	↗	
	2:18m	9.4	↘	
	2:43m	8.9	↙	
Serie		94 (4x)		
Total		184 (5x)		
Press 3 serie 	41.1s	10.3	↓	
	57.9s	10.1	↑	
	1:43m	10.1	↓	
	2:09m	9.8	←	
	2:33m	8.3	➔	
	13.8s	9.9	↓	
	1:15m	9.5	➔	
	2:08m	10.6x	↓	
	2:32m	9.1	↗	
	2:56m	9.3	↙	
Serie		93 (1x)		
Total		277 (6x)		

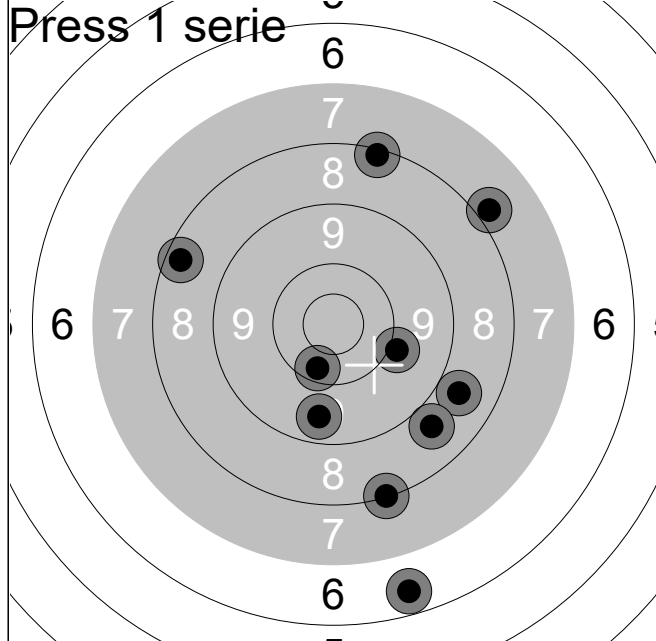

15.7s	8.8	↘
34.1s	8.8	↘
55.5s	9.6	↓
1:16m	6.5	↓
1:42m	8.1	↓
15.3s	10.0	→
44.4s	7.9	↗
1:09m	8.2	↑
1:52m	10.3	↓
2:22m	8.4	↖
Serie	82 (0x)	
Total	82 (0x)	

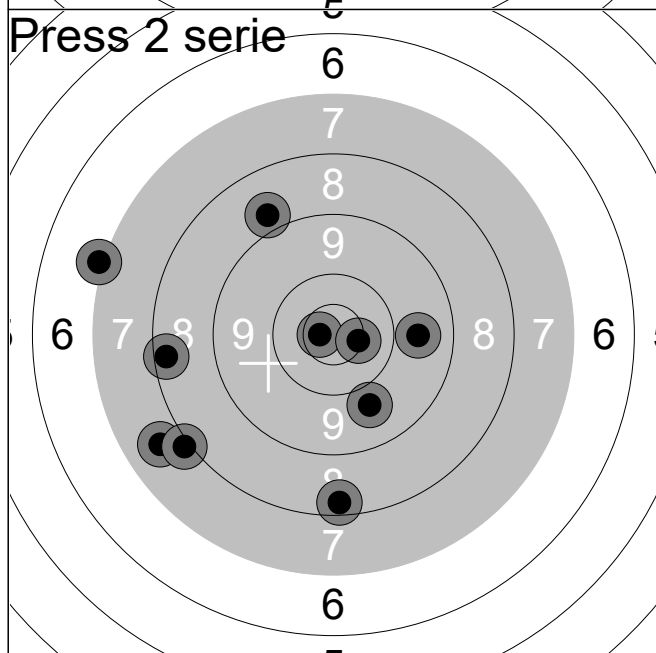

11.0s	7.7	↖
32.0s	8.0	↖
1:00m	10.8x	←
1:19m	7.1	↖
1:44m	8.9	↗
20.8s	8.3	↓
41.1s	9.7	→
1:04m	9.8	↓
1:29m	10.6x	→
2:01m	8.3	←
Serie	84 (2x)	
Total	166 (2x)	

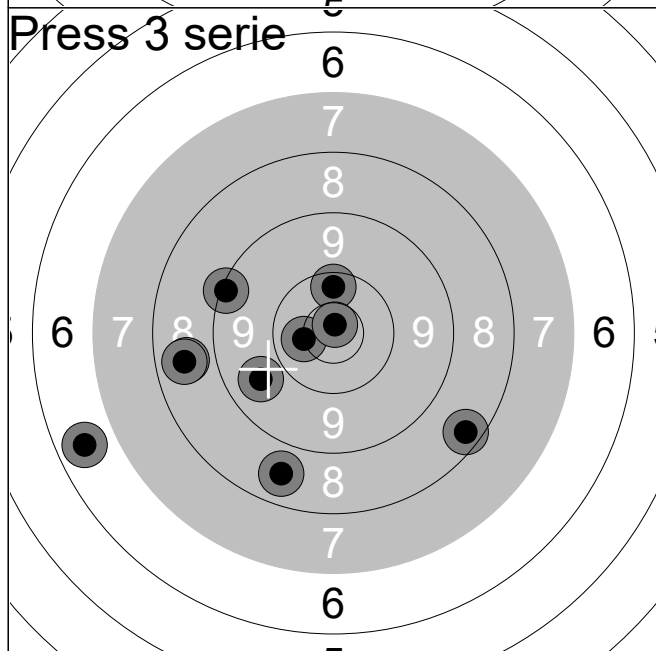

12.2s	8.7	←
31.1s	10.5x	←
51.8s	8.7	↓
1:42m	6.6	↖
2:29m	8.6	←
12.3s	10.3	↑
29.7s	10.8x	↑
51.4s	9.2	↖
1:11m	8.4	↘
1:39m	9.7	↖
Serie	86 (2x)	
Total	252 (4x)	

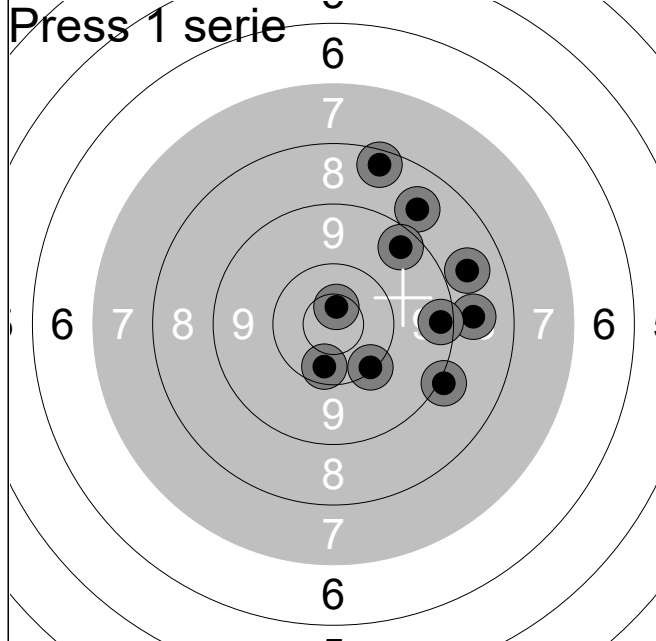

23.6s	10.3	↓
1:15m	8.8	→
1:45m	10.2	↘
2:16m	8.4	↑
2:51m	8.7	→
1:38m	9.1	↘
2:08m	8.8	↗
2:29m	10.7x	↑
2:54m	9.4	→
3:27m	9.4	↗
Serie		89 (1x)
Total		89 (1x)

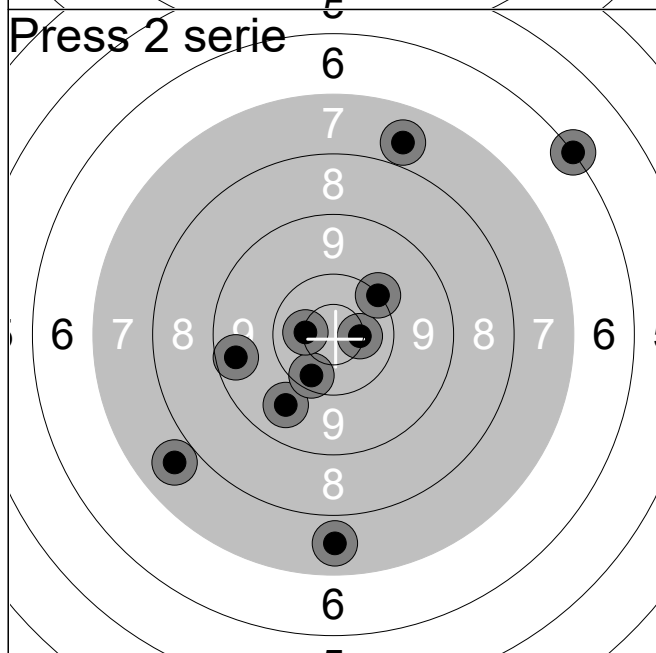

53.0s	7.7	↓
2:11m	9.7	↓
2:33m	10.3	↓
3:23m	10.6x	→
3:55m	10.1	↗
36.6s	10.6x	←
2:48m	9.5	←
3:02m	7.7	↑
3:24m	7.8	↙
3:41m	6.1	↗
Serie		85 (2x)
Total		174 (3x)

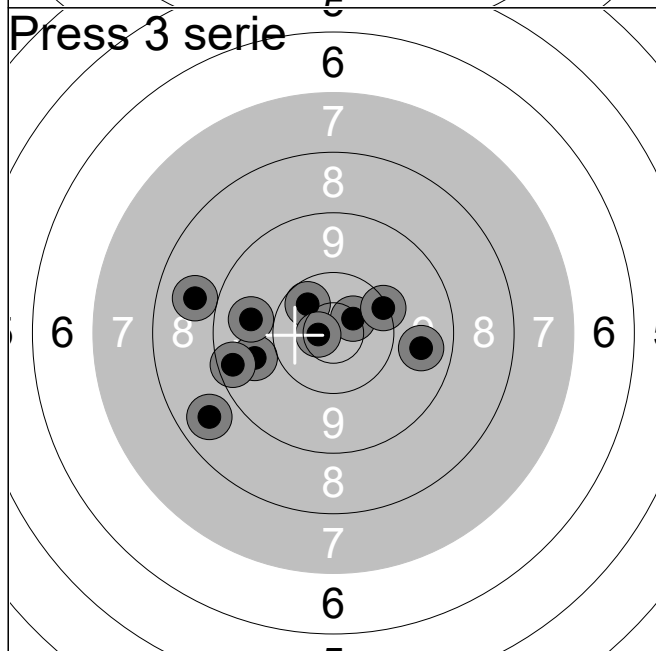

10.6s	10.6x	↗
1:17m	10.4x	↖
2:35m	10.2	↗
3:24m	9.8	←
3:50m	10.7x	←
12.2s	8.7	↙
1:24m	9.8	←
1:45m	9.7	→
3:14m	9.4	←
3:37m	8.8	←
Serie		92 (3x)
Total		266 (6x)

25.06.2019	NM bane 2019	NM Pistol 2019
------------	--------------	----------------

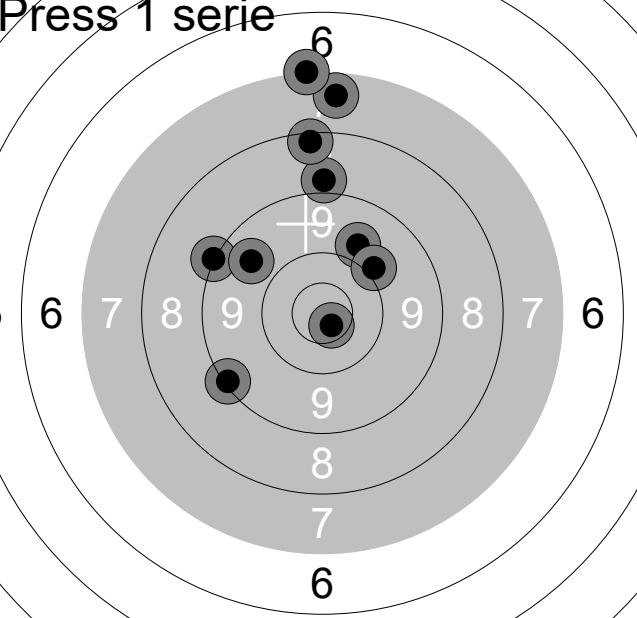
Press 1 serie 	<table style="width:100%; border-collapse: collapse;"> <tr><td style="width:15%;">15.5s</td><td style="width:15%;">7.5</td><td style="width:15%; text-align: center;">↑</td></tr> <tr><td>58.0s</td><td>9.2</td><td style="text-align: center;">↙</td></tr> <tr><td>1:39m</td><td>9.1</td><td style="text-align: center;">↖</td></tr> <tr><td>2:21m</td><td>7.1</td><td style="text-align: center;">↑</td></tr> <tr><td>3:22m</td><td>10.7x</td><td style="text-align: center;">↘</td></tr> <tr><td>21.1s</td><td>8.9</td><td style="text-align: center;">↑</td></tr> <tr><td>57.6s</td><td>9.9</td><td style="text-align: center;">↗</td></tr> <tr><td>1:41m</td><td>8.3</td><td style="text-align: center;">↑</td></tr> <tr><td>2:25m</td><td>10.0</td><td style="text-align: center;">↗</td></tr> <tr><td>3:06m</td><td>9.7</td><td style="text-align: center;">↖</td></tr> <tr style="border-top: 1px solid black;"><td style="border-top: 1px solid black;">Serie</td><td style="border-top: 1px solid black;">86 (1x)</td><td></td></tr> <tr><td>Total</td><td>86 (1x)</td><td></td></tr> </table>	15.5s	7.5	↑	58.0s	9.2	↙	1:39m	9.1	↖	2:21m	7.1	↑	3:22m	10.7x	↘	21.1s	8.9	↑	57.6s	9.9	↗	1:41m	8.3	↑	2:25m	10.0	↗	3:06m	9.7	↖	Serie	86 (1x)		Total	86 (1x)	
15.5s	7.5	↑																																			
58.0s	9.2	↙																																			
1:39m	9.1	↖																																			
2:21m	7.1	↑																																			
3:22m	10.7x	↘																																			
21.1s	8.9	↑																																			
57.6s	9.9	↗																																			
1:41m	8.3	↑																																			
2:25m	10.0	↗																																			
3:06m	9.7	↖																																			
Serie	86 (1x)																																				
Total	86 (1x)																																				

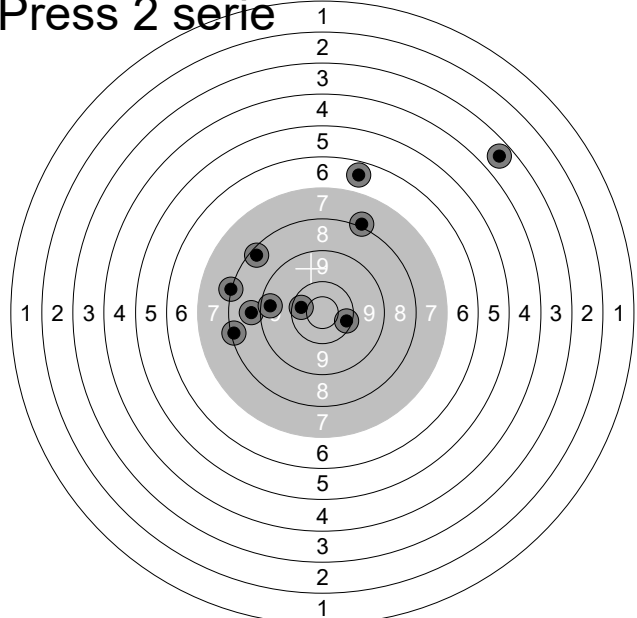
Press 2 serie 	<table style="width:100%; border-collapse: collapse;"> <tr><td style="width:15%;">34.4s</td><td style="width:15%;">3.6</td><td style="width:15%; text-align: center;">↗</td></tr> <tr><td>1:18m</td><td>6.6</td><td style="text-align: center;">↑</td></tr> <tr><td>2:06m</td><td>8.9</td><td style="text-align: center;">←</td></tr> <tr><td>2:51m</td><td>10.3</td><td style="text-align: center;">→</td></tr> <tr><td>3:35m</td><td>8.1</td><td style="text-align: center;">←</td></tr> <tr><td>26.1s</td><td>9.5</td><td style="text-align: center;">←</td></tr> <tr><td>1:06m</td><td>8.0</td><td style="text-align: center;">↗</td></tr> <tr><td>1:55m</td><td>10.4</td><td style="text-align: center;">←</td></tr> <tr><td>2:41m</td><td>8.2</td><td style="text-align: center;">←</td></tr> <tr><td>3:27m</td><td>8.4</td><td style="text-align: center;">↗</td></tr> <tr style="border-top: 1px solid black;"><td style="border-top: 1px solid black;">Serie</td><td style="border-top: 1px solid black;">78 (0x)</td><td></td></tr> <tr><td>Total</td><td>164 (1x)</td><td></td></tr> </table>	34.4s	3.6	↗	1:18m	6.6	↑	2:06m	8.9	←	2:51m	10.3	→	3:35m	8.1	←	26.1s	9.5	←	1:06m	8.0	↗	1:55m	10.4	←	2:41m	8.2	←	3:27m	8.4	↗	Serie	78 (0x)		Total	164 (1x)	
34.4s	3.6	↗																																			
1:18m	6.6	↑																																			
2:06m	8.9	←																																			
2:51m	10.3	→																																			
3:35m	8.1	←																																			
26.1s	9.5	←																																			
1:06m	8.0	↗																																			
1:55m	10.4	←																																			
2:41m	8.2	←																																			
3:27m	8.4	↗																																			
Serie	78 (0x)																																				
Total	164 (1x)																																				

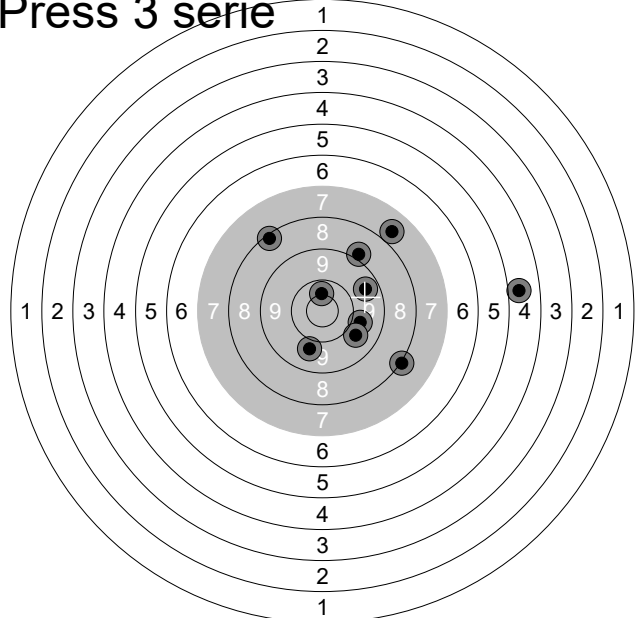
Press 3 serie 	<table style="width:100%; border-collapse: collapse;"> <tr><td style="width:15%;">20.3s</td><td style="width:15%;">8.3</td><td style="width:15%; text-align: center;">↗</td></tr> <tr><td>56.5s</td><td>9.9</td><td style="text-align: center;">→</td></tr> <tr><td>1:33m</td><td>9.0</td><td style="text-align: center;">↗</td></tr> <tr><td>2:14m</td><td>10.5x</td><td style="text-align: center;">↑</td></tr> <tr><td>3:01m</td><td>9.9</td><td style="text-align: center;">↘</td></tr> <tr><td>21.0s</td><td>8.1</td><td style="text-align: center;">↘</td></tr> <tr><td>1:06m</td><td>7.7</td><td style="text-align: center;">↗</td></tr> <tr><td>1:49m</td><td>4.8</td><td style="text-align: center;">→</td></tr> <tr><td>2:33m</td><td>9.6</td><td style="text-align: center;">↗</td></tr> <tr><td>3:15m</td><td>9.8</td><td style="text-align: center;">↘</td></tr> <tr style="border-top: 1px solid black;"><td style="border-top: 1px solid black;">Serie</td><td style="border-top: 1px solid black;">82 (1x)</td><td></td></tr> <tr><td>Total</td><td>246 (2x)</td><td></td></tr> </table>	20.3s	8.3	↗	56.5s	9.9	→	1:33m	9.0	↗	2:14m	10.5x	↑	3:01m	9.9	↘	21.0s	8.1	↘	1:06m	7.7	↗	1:49m	4.8	→	2:33m	9.6	↗	3:15m	9.8	↘	Serie	82 (1x)		Total	246 (2x)	
20.3s	8.3	↗																																			
56.5s	9.9	→																																			
1:33m	9.0	↗																																			
2:14m	10.5x	↑																																			
3:01m	9.9	↘																																			
21.0s	8.1	↘																																			
1:06m	7.7	↗																																			
1:49m	4.8	→																																			
2:33m	9.6	↗																																			
3:15m	9.8	↘																																			
Serie	82 (1x)																																				
Total	246 (2x)																																				

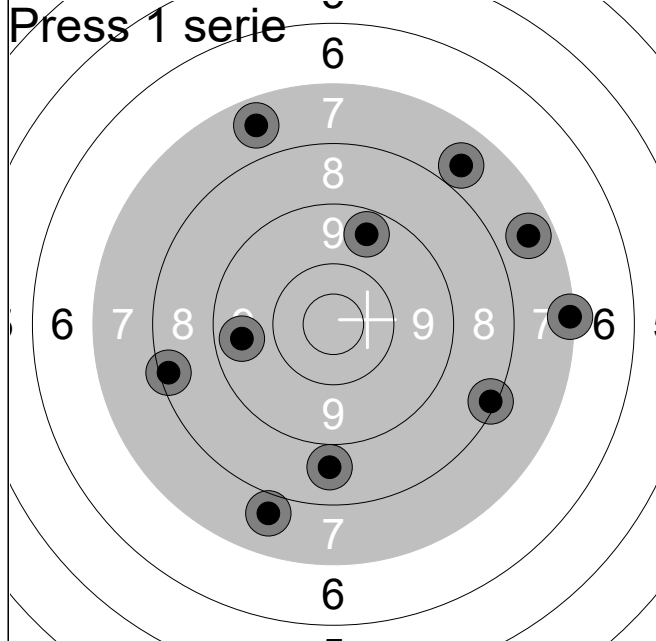

10.7s	7.8	↗
55.0s	8.3	←
1:33m	9.6	↗
2:28m	7.6	↗
3:00m	7.6	↗
12.6s	7.2	→
42.2s	9.6	←
1:04m	7.8	↓
1:40m	8.2	↘
2:21m	8.8	↓

Serie	77 (0x)
Total	77 (0x)

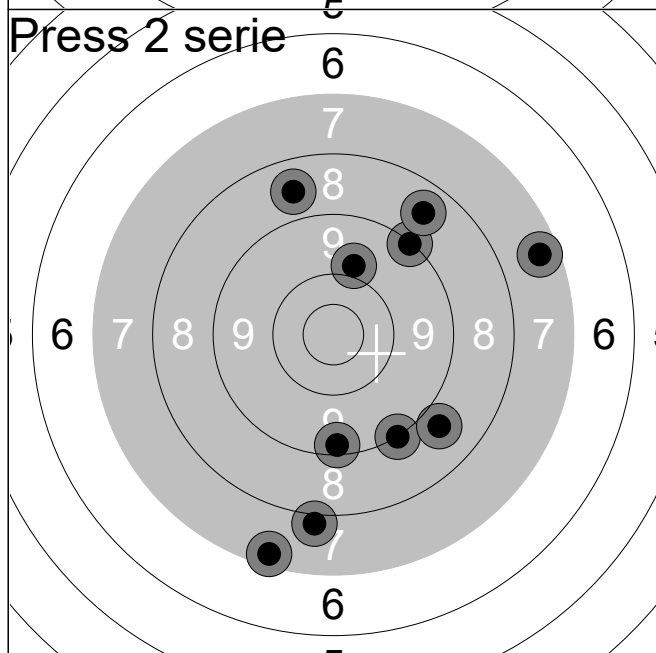

38.6s	9.2	↗
1:14m	8.6	↗
1:51m	9.1	↓
2:27m	8.0	↓
3:43m	9.9	↗
23.2s	8.7	↗
4:20m	7.5	↗
4:24m	9.3	↓
4:39m	7.3	↓
4:42m	8.8	↘

Serie	82 (0x)
Total	159 (0x)

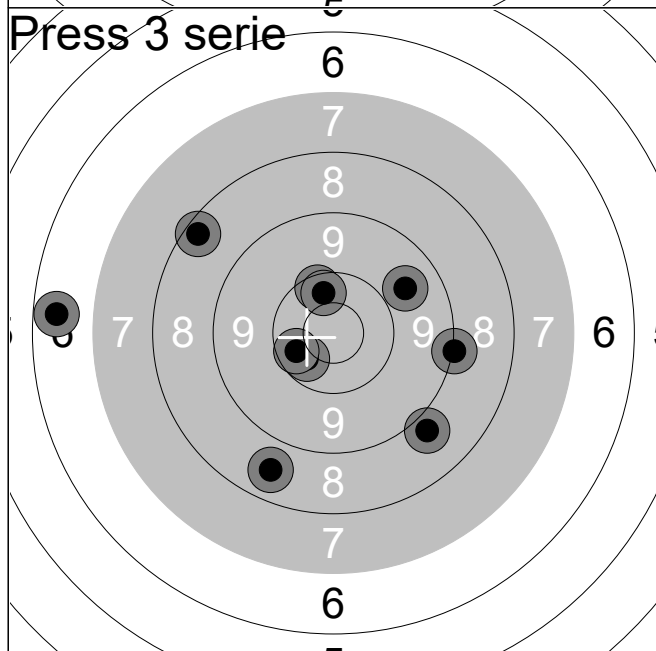

13.8s	8.6	↓
45.7s	9.7	↗
1:12m	10.4x	↘
1:36m	10.4x	←
2:11m	8.4	↗
8.36s	9.1	→
35.6s	8.9	↘
1:15m	10.3	↗
1:43m	6.5	←
2:13m	10.4x	↗

Serie	88 (3x)
Total	247 (3x)

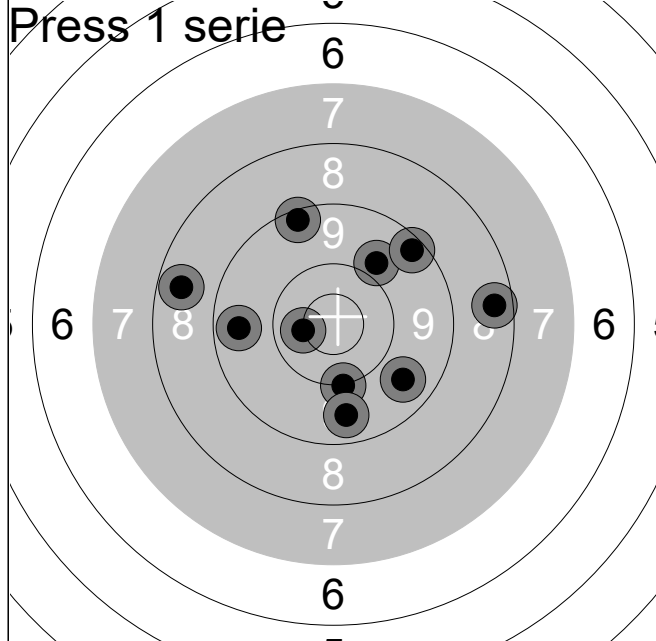

24.8s	9.7	↘
56.6s	9.9	↗
1:38m	10.5x	←
2:15m	10.1	↓
2:54m	9.3	↗
36.1s	9.3	↑
1:15m	8.5	←
1:50m	9.6	←
2:28m	8.5	→
3:06m	9.6	↓

Serie	90 (1x)
--------------	-----------------

Total	90 (1x)
--------------	-----------------

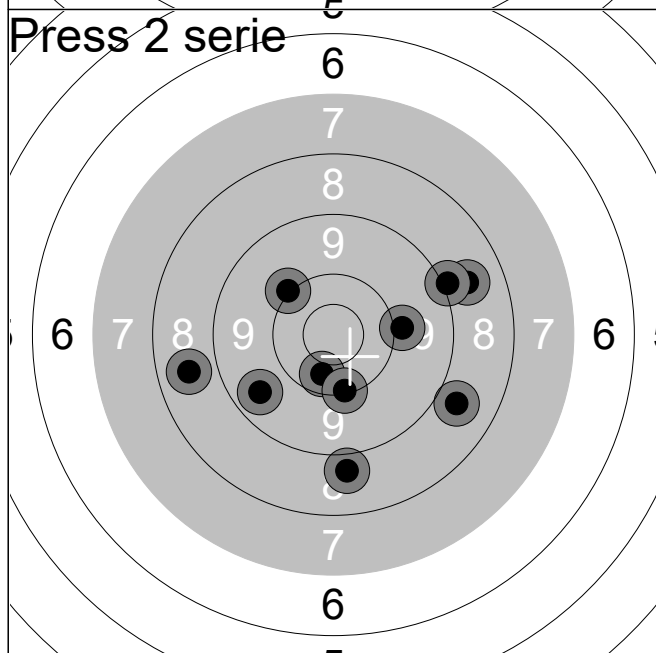

32.1s	8.8	→
1:02m	10.1	↗
1:37m	8.7	←
2:06m	10.0	→
2:40m	9.6	↙
52.4s	9.1	→
1:29m	10.4x	↓
1:57m	10.2	↓
2:31m	8.9	↓
3:10m	8.8	↘

Serie	90 (1x)
--------------	-----------------

Total	180 (2x)
--------------	------------------

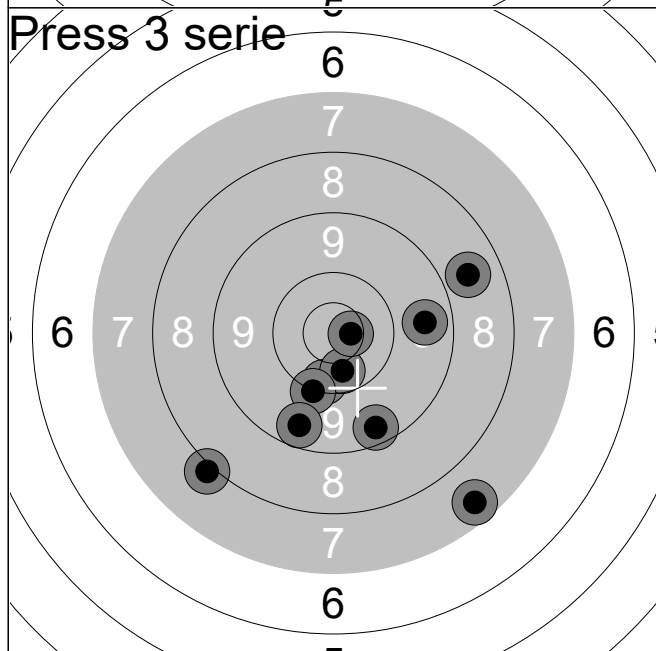

45.5s	9.4	↓
1:19m	10.3	↓
1:57m	7.5	↘
2:26m	10.4x	↓
3:01m	9.6	→
30.3s	8.7	↗
58.3s	10.7x	→
1:33m	8.0	↙
2:27m	10.1	↓
3:03m	9.5	↓

Serie	90 (2x)
--------------	-----------------

Total	270 (4x)
--------------	------------------

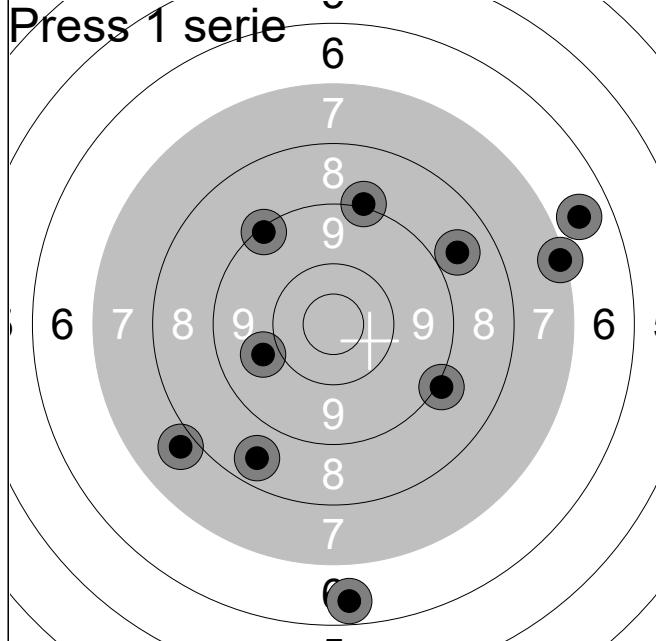

17.7s	9.2	↗
40.3s	9.9	←
1:09m	6.5	↓
1:50m	8.6	↓
2:13m	7.9	←
14.5s	8.8	↗
39.2s	7.2	→
1:02m	9.1	↑
1:30m	9.1	↘
1:56m	6.7	→
Serie	78 (0x)	
Total	78 (0x)	

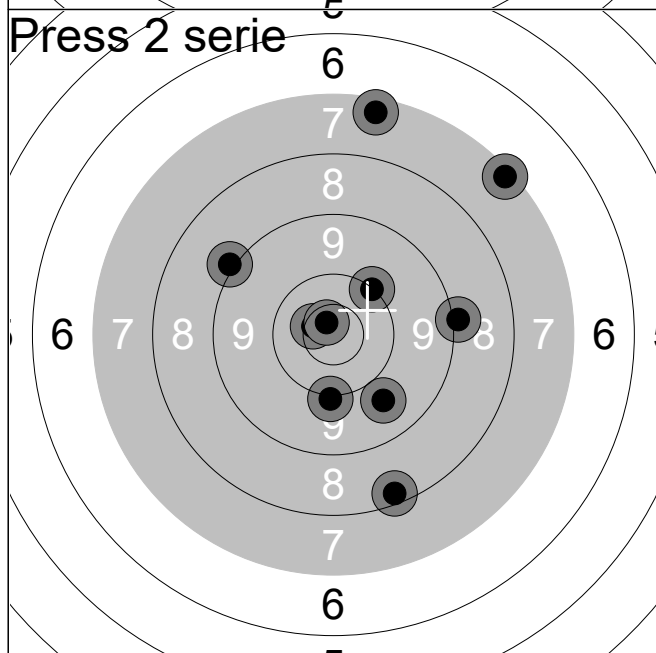

14.7s	8.3	↓
38.4s	7.3	↗
1:02m	9.8	↓
1:31m	9.1	↗
2:02m	10.6x	←
11.9s	7.4	↑
45.1s	10.1	↓
1:19m	10.8x	↗
1:53m	10.1	↗
2:23m	9.0	→
Serie	89 (2x)	
Total	167 (2x)	

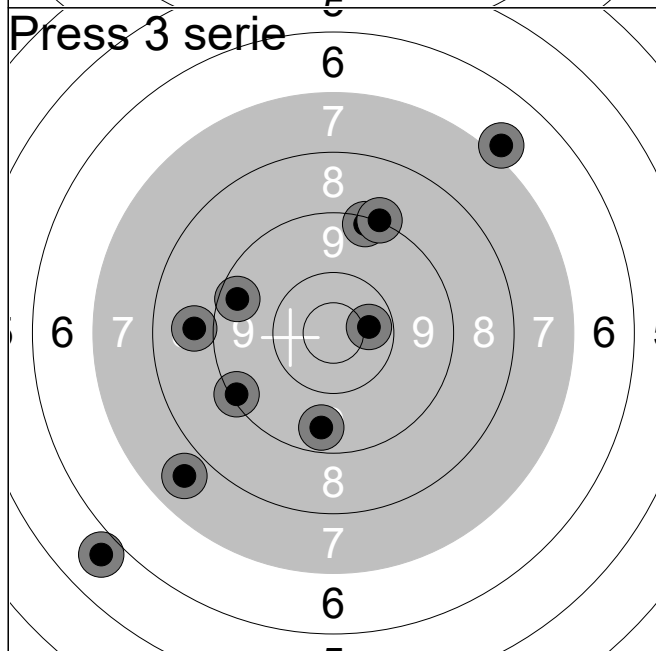

14.8s	9.2	↑
37.7s	6.9	↗
1:02m	7.7	↘
1:45m	8.8	←
2:11m	10.4x	→
16.0s	9.6	↓
46.7s	9.2	←
1:13m	9.1	↗
1:44m	5.8	↘
2:10m	9.4	←
Serie	81 (1x)	
Total	248 (3x)	

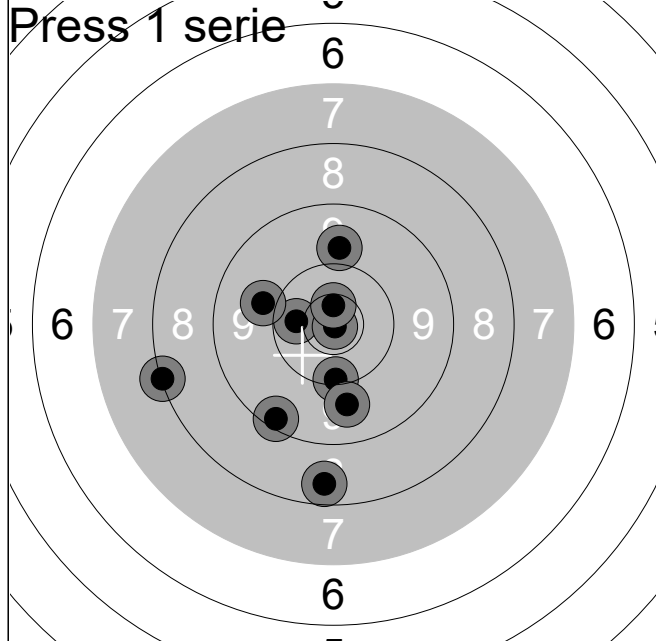

	25.7s	8.5			↓
	1:02m	10.4x			←
	1:46m	9.9			←
	2:32m	10.2			↓
	3:18m	10.9x			↘
	25.1s	10.7x			↑
	1:28m	9.9			↑
	1:49m	9.8			↓
	2:40m	8.2			←
	3:21m	9.3			↘
Serie					92 (3x)
Total					92 (3x)

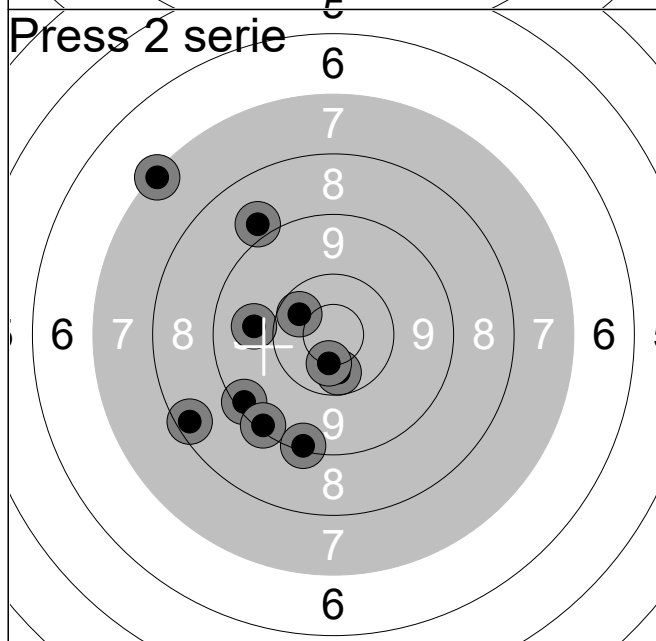

	13.9s	10.4x			↓
	52.6s	8.3			↙
	1:29m	9.3			↙
	2:06m	9.8			←
	2:46m	8.9			↗
	15.6s	9.2			↘
	47.1s	9.2			↓
	1:17m	10.4x			↙
	1:43m	10.5x			↓
	2:31m	7.2			↗
Serie					89 (3x)
Total					181 (6x)

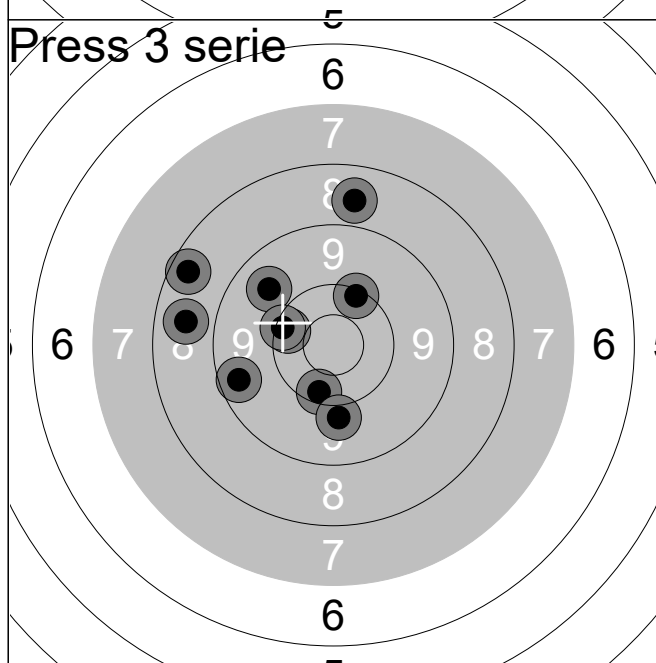

	12.6s	10.3			↓
	53.2s	10.3			←
	1:43m	9.5			←
	2:22m	9.7			↗
	2:55m	8.7			↑
	25.0s	9.9			↓
	54.5s	8.7			←
	1:33m	10.2			←
	2:06m	8.4			↙
	3:04m	10.2			↑
Serie					91 (0x)
Total					272 (6x)

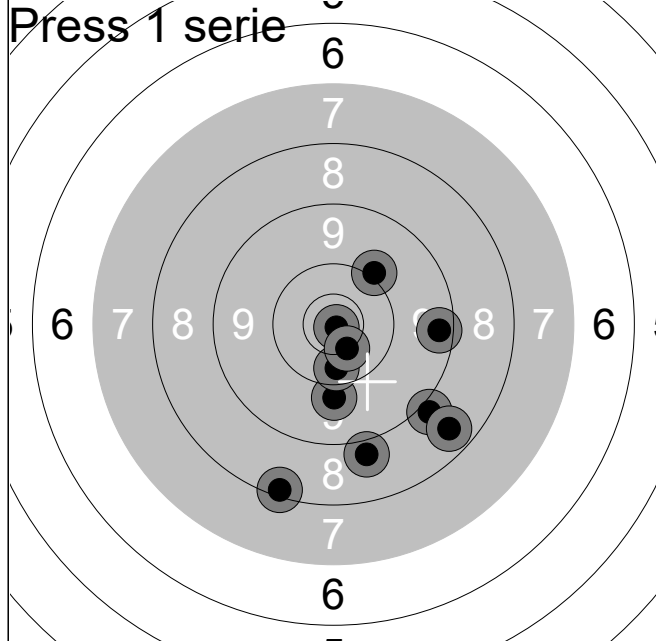

19.2s	9.4	→
1:05m	8.9	↓
1:46m	10.0	↗
2:33m	8.2	↓
3:14m	9.9	↓
19.3s	9.0	↓
1:02m	8.5	↓
1:47m	10.9x	↓
2:30m	10.3	↓
4:04m	10.6x	↓
Serie	91 (2x)	
Total	91 (2x)	

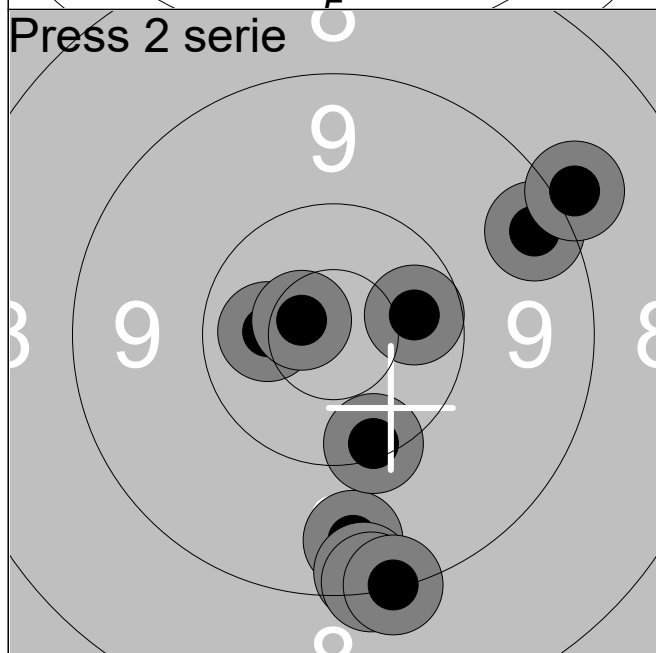

22.1s	9.6	↓
1:08m	9.3	↓
1:51m	9.2	↓
2:40m	10.2	↓
3:18m	9.4	↗
20.1s	9.2	↓
1:05m	10.5x	←
1:48m	10.7x	↖
2:31m	9.0	↗
3:17m	10.4x	→
Serie	94 (3x)	
Total	185 (5x)	

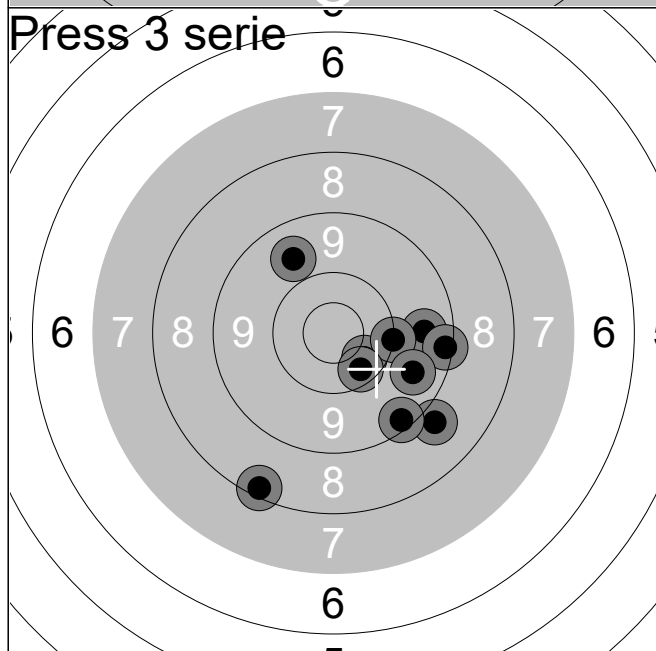

20.1s	9.7	↗
57.9s	8.3	↓
1:40m	10.4x	↓
2:33m	8.9	↓
3:20m	9.6	→
19.2s	9.3	→
1:03m	10.1	→
1:48m	9.7	↓
2:37m	10.3	↓
3:44m	9.3	↓
Serie	91 (1x)	
Total	276 (6x)	

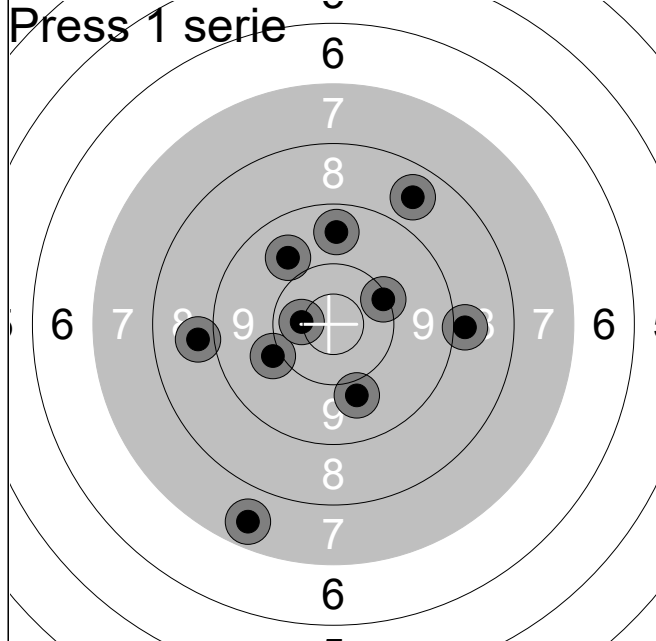

10.2s	9.8	↖
32.5s	8.6	↗
1:01m	10.2	↘
1:33m	9.6	↑
2:13m	9.0	→
10.1s	9.9	↓
44.7s	10.0	↙
1:20m	8.9	←
1:54m	7.6	↘
2:25m	10.5x	←

Serie	89 (1x)
Total	89 (1x)

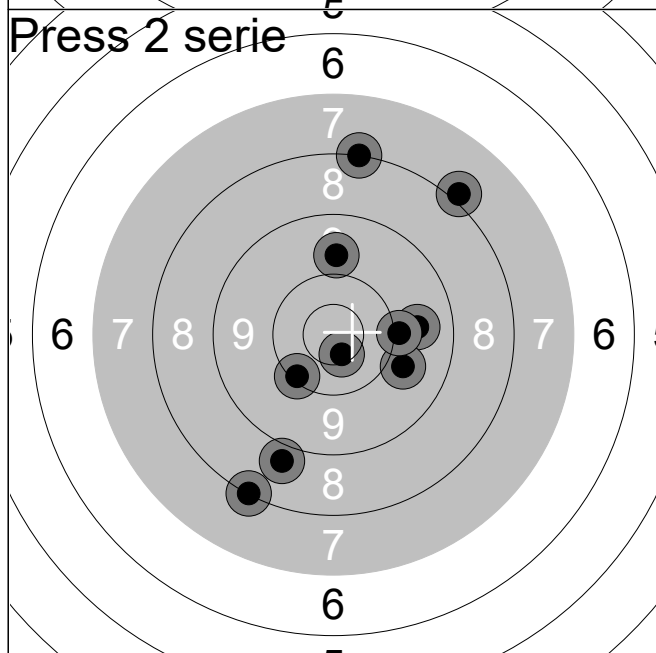

7.17s	8.0	↗
41.2s	10.2	↙
1:07m	9.8	↑
1:43m	8.9	↘
2:17m	8.2	↘
10.3s	9.7	→
42.3s	9.9	↘
1:17m	8.1	↑
1:51m	10.0	→
2:31m	10.7x	↘

Serie	89 (1x)
Total	178 (2x)

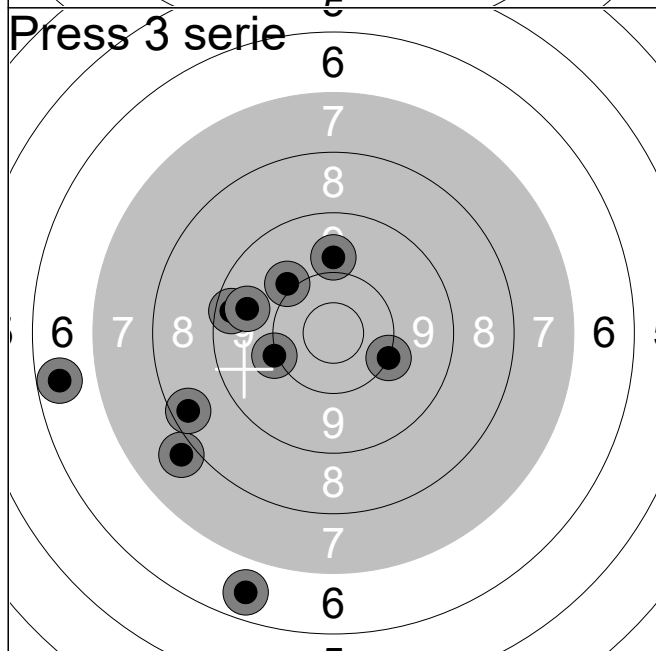

8.92s	6.5	←
41.0s	7.9	↙
1:11m	9.4	←
1:37m	10.1	↙
2:22m	9.9	↑
10.3s	6.6	↘
41.5s	10.1	↘
1:25m	9.7	←
2:04m	10.0	↗
2:55m	8.4	↙

Serie	84 (0x)
Total	262 (2x)

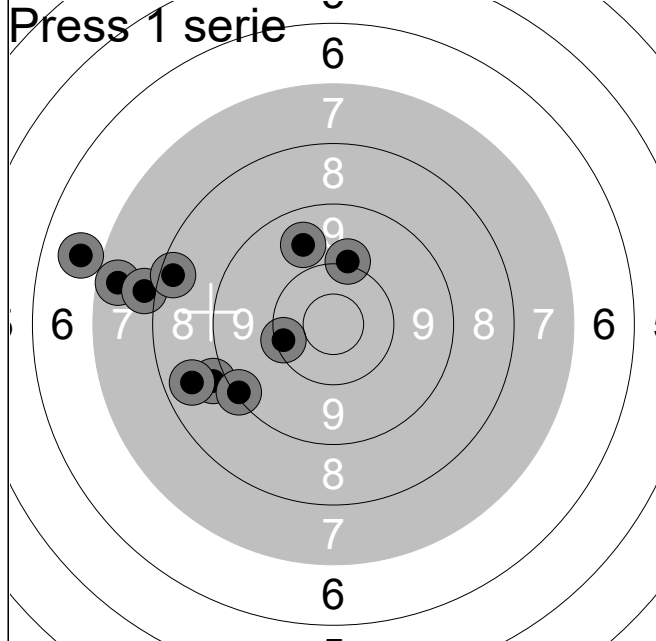

18.5s	7.5	←
48.9s	8.9	←
1:33m	10.2	←
2:11m	7.9	←
2:49m	6.8	←
16.8s	10.0	↑
53.5s	8.6	←
1:41m	9.7	↑
2:25m	9.2	←
3:14m	8.4	←
Serie		82 (0x)
Total		82 (0x)

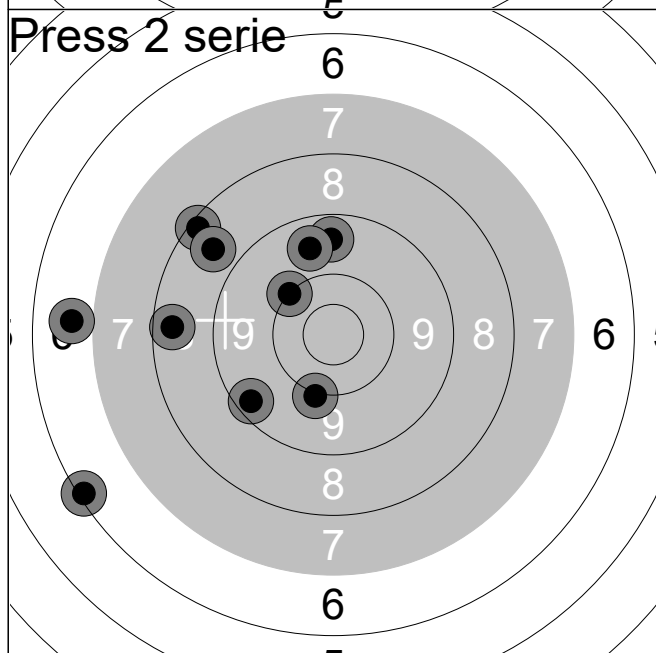

21.3s	8.5	←
1:03m	9.4	←
1:44m	9.6	↑
2:30m	10.1	↖
3:22m	6.2	←
18.1s	8.3	↖
1:00m	9.7	↑
1:35m	10.1	↓
2:07m	8.7	↖
2:50m	6.8	←
Serie		83 (0x)
Total		165 (0x)

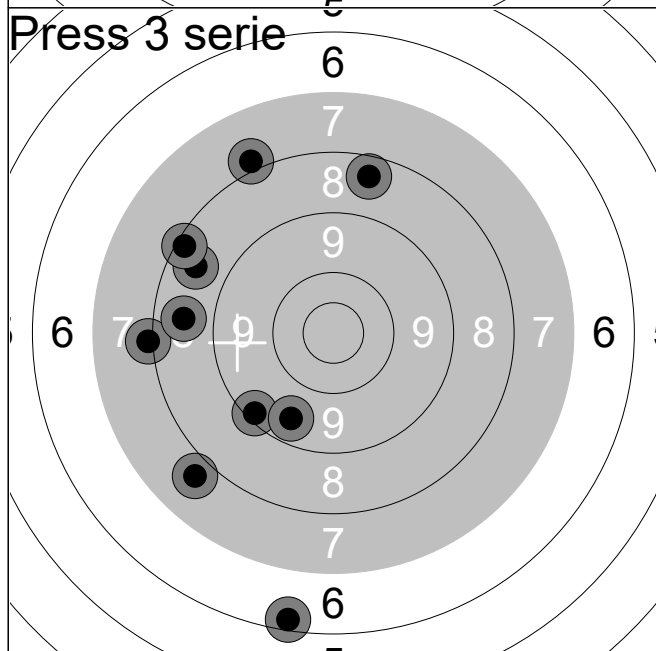

12.4s	8.6	←
43.8s	8.5	↑
1:24m	8.3	↖
1:56m	7.8	←
2:36m	8.1	←
14.8s	6.3	↓
54.4s	8.6	←
1:40m	9.3	←
2:19m	9.6	↓
2:59m	8.0	↑
Serie		79 (0x)
Total		244 (0x)

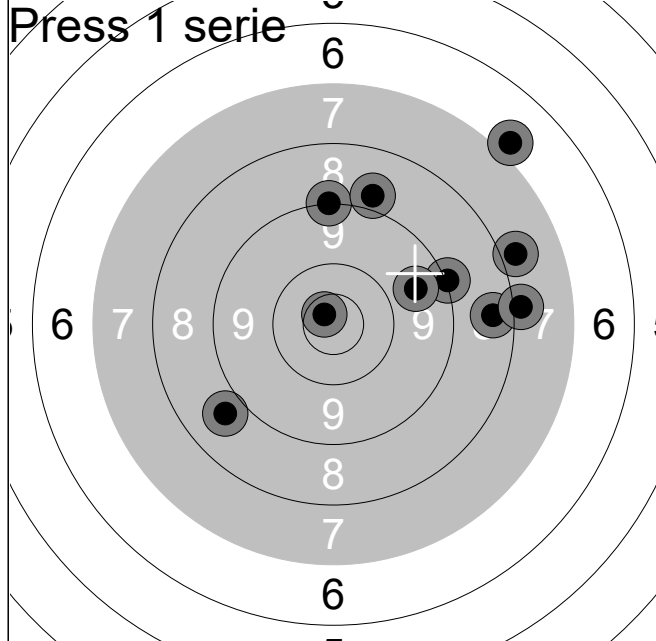

11.0s	10.8x	↖
24.7s	9.1	↑
41.5s	8.9	↑
1:03m	9.1	→
1:12m	6.9	↗
21.3s	8.8	↙
36.3s	9.6	→
1:00m	8.5	→
1:32m	8.0	→
1:54m	7.9	→
Serie		82 (1x)
Total		82 (1x)

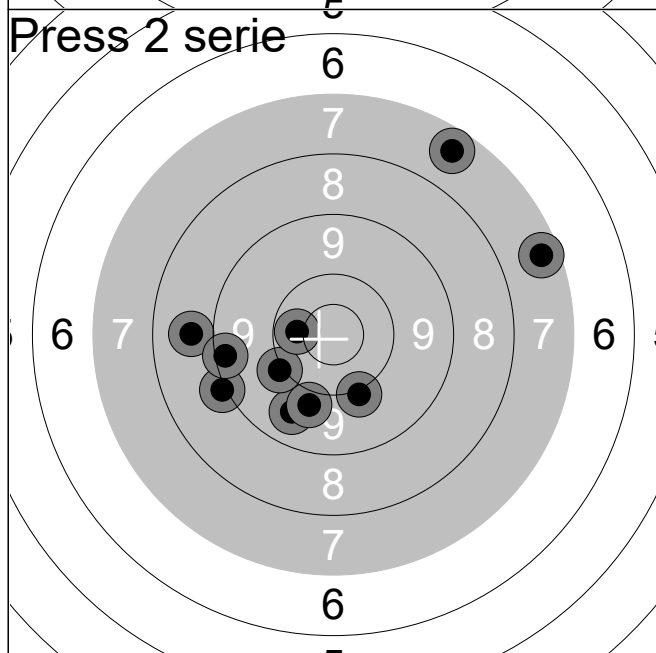

13.9s	7.4	→
26.5s	7.5	↗
1:04m	9.7	↓
1:20m	9.1	↙
1:48m	8.8	←
8.23s	9.3	←
23.5s	9.9	↓
39.3s	10.1	↙
57.6s	10.4x	←
1:18m	10.0	↓
Serie		88 (1x)
Total		170 (2x)

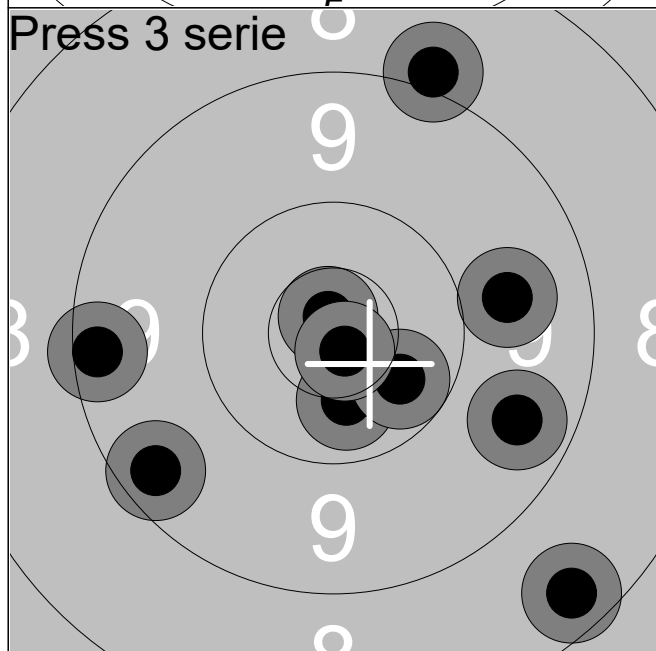

11.6s	9.3	←
27.7s	9.8	→
45.7s	10.5x	↓
1:16m	10.4x	↘
1:51m	10.8x	↑
26.4s	9.6	→
54.2s	9.4	↙
1:16m	9.0	↗
1:40m	10.8x	↓
2:10m	8.4	↘
Serie		93 (4x)
Total		263 (6x)

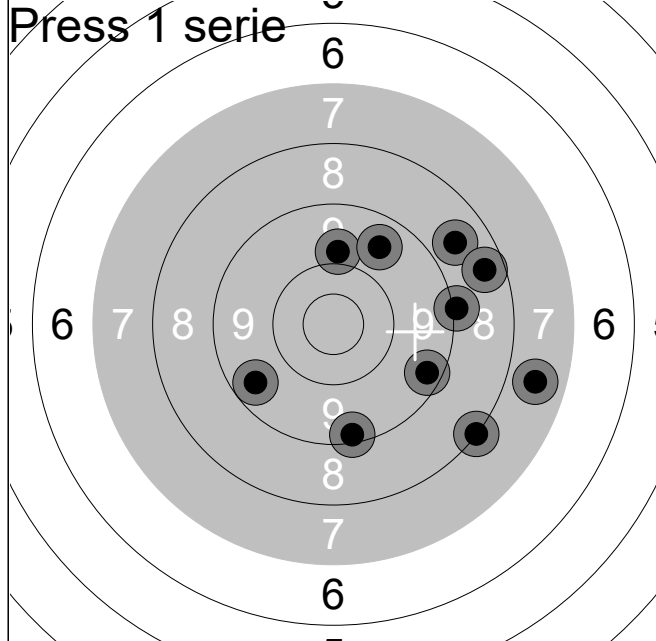

17.1s	8.7	↗
44.9s	9.4	↘
1:07m	8.5	↗
1:38m	7.7	→
1:57m	9.5	↖
11.5s	9.9	↑
48.8s	9.3	↓
1:24m	9.6	↗
1:55m	9.1	→
2:18m	8.1	↘

Serie	85 (0x)
-------	----------

Total	85 (0x)
-------	----------

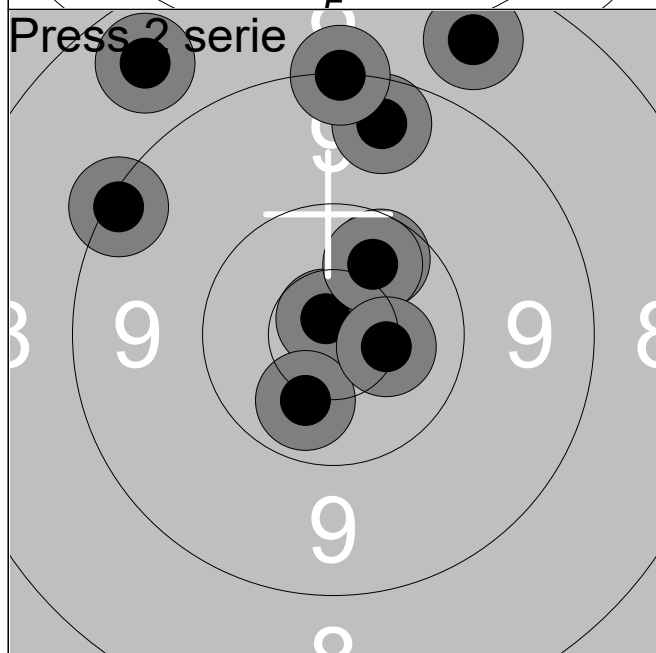

14.3s	10.4x	↗
1:08m	10.8x	↖
1:37m	9.5	↑
2:05m	10.4x	↗
2:36m	8.6	↗
17.7s	10.5x	↓
52.2s	9.2	↑
1:23m	10.6x	→
1:55m	9.2	↖
2:21m	8.6	↗

Serie	93 (5x)
-------	----------

Total	178 (5x)
-------	-----------

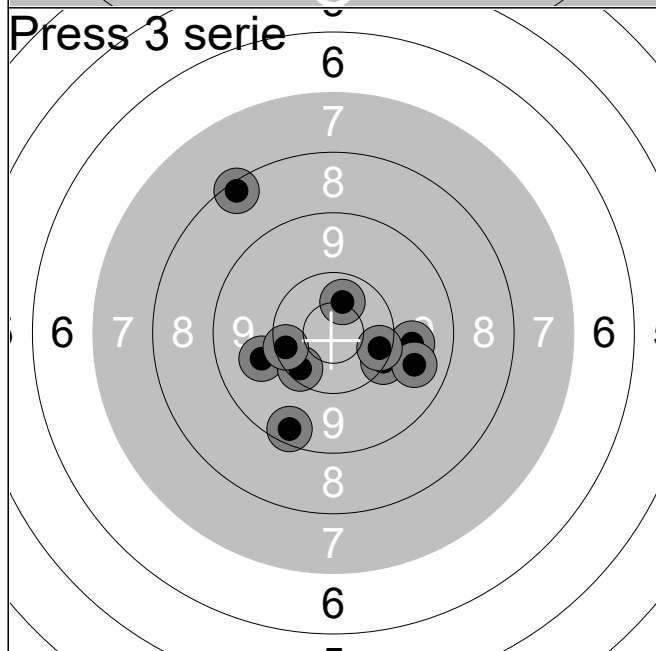

13.0s	10.1	↘
39.8s	9.8	→
1:10m	10.5x	↗
1:41m	9.4	↓
2:08m	8.3	↗
15.6s	9.9	↖
1:07m	9.7	→
1:33m	10.3	↖
2:01m	10.3	→
2:30m	10.3	↖

Serie	94 (1x)
-------	----------

Total	272 (6x)
-------	-----------

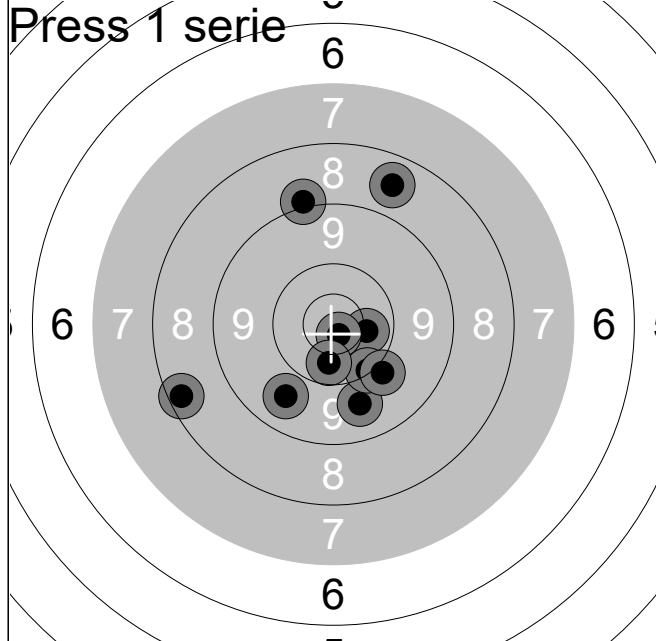

16.8s	10.5x	→
49.9s	9.7	↓
1:58m	9.0	↑
2:27m	10.1	↓
3:32m	8.3	←
34.3s	8.6	↑
1:06m	10.0	↓
1:42m	10.8x	↓
2:20m	9.7	↓
2:52m	10.4x	↓
Serie	93 (3x)	
Total	93 (3x)	

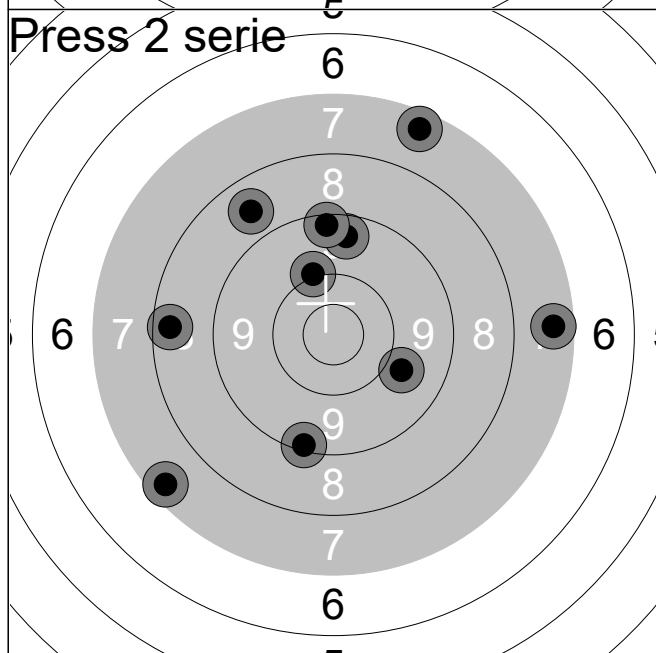

13.3s	7.4	↑
55.9s	7.5	→
2:08m	9.5	↑
2:42m	9.9	→
3:08m	10.1	↑
17.3s	8.7	↑
1:16m	9.2	↓
1:48m	7.4	←
2:51m	8.4	←
3:15m	9.3	↑
Serie	83 (0x)	
Total	176 (3x)	

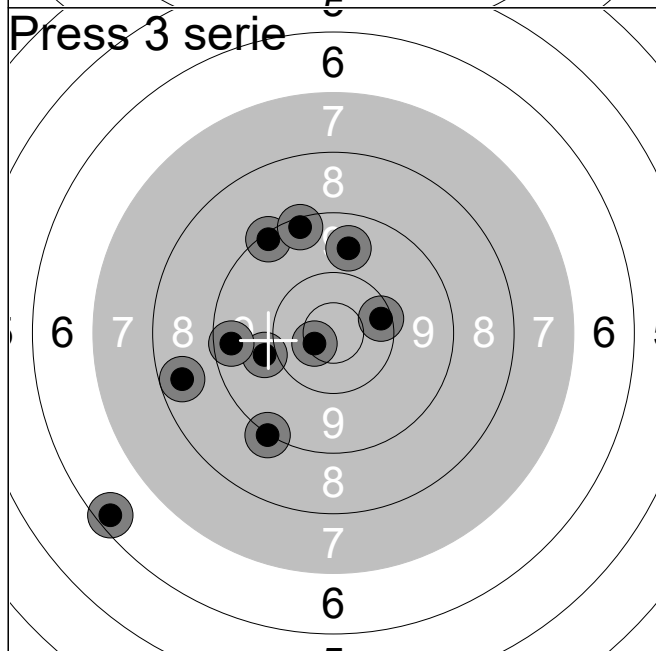

25.6s	9.2	↖
1:26m	6.3	↙
1:46m	10.6x	↙
2:08m	9.9	←
2:27m	9.3	↑
46.5s	10.3	→
1:11m	9.7	↑
1:34m	8.5	←
2:02m	9.1	↓
2:26m	9.4	←
Serie	88 (1x)	
Total	264 (4x)	

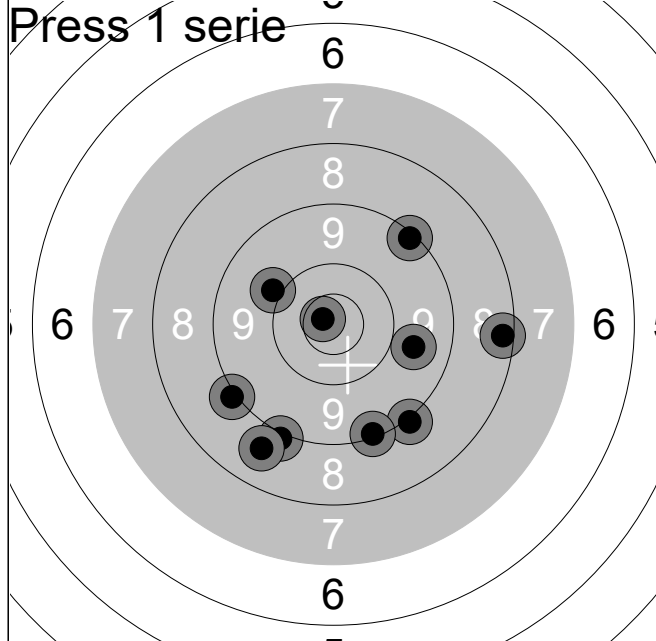

9.57s	9.8	→
35.5s	9.1	↓
1:05m	10.0	↗
1:33m	8.3	→
1:59m	9.0	↓
19.1s	9.2	↗
48.9s	9.1	↖
1:19m	9.2	↓
1:58m	8.8	↘
2:26m	10.8x	↖

Serie 90 (1x)

Total 90 (1x)

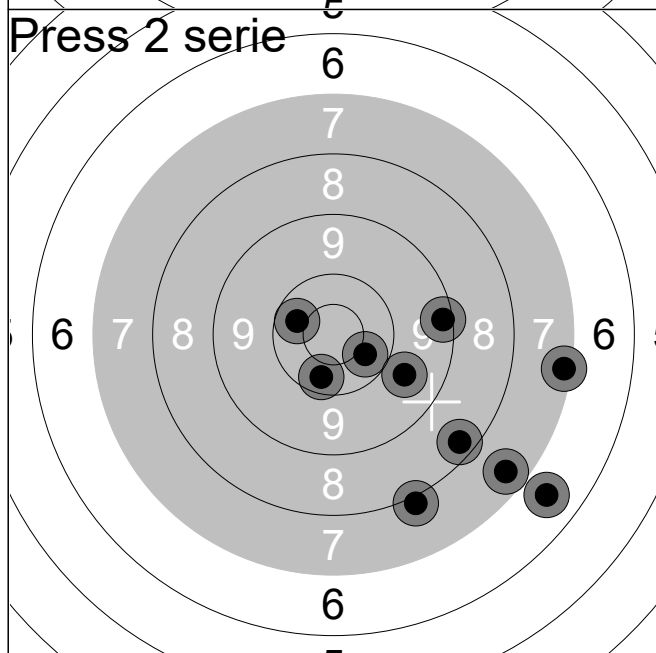

11.2s	10.4x	↘
33.3s	7.5	↘
1:07m	10.4x	↗
1:42m	9.8	↘
2:16m	10.3	↓
9.88s	8.0	↘
40.3s	8.4	↘
1:14m	6.7	↘
1:43m	7.3	→
2:09m	9.3	→

Serie 84 (2x)

Total 174 (3x)

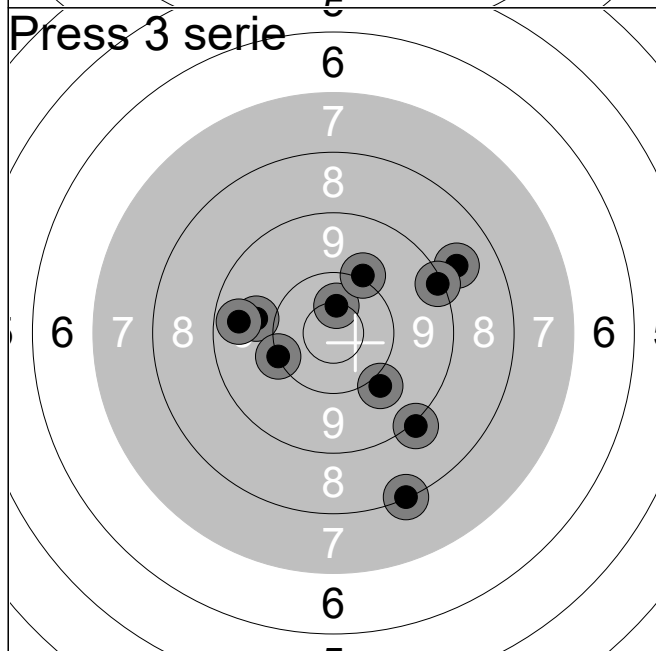

21.3s	8.8	↗
49.8s	10.6x	↑
1:24m	9.8	↖
2:01m	9.1	↘
2:31m	10.0	↗
23.4s	8.2	↘
46.2s	10.0	↘
1:17m	9.2	↗
1:51m	10.1	↖
2:25m	9.6	↖

Serie 92 (1x)

Total 266 (4x)

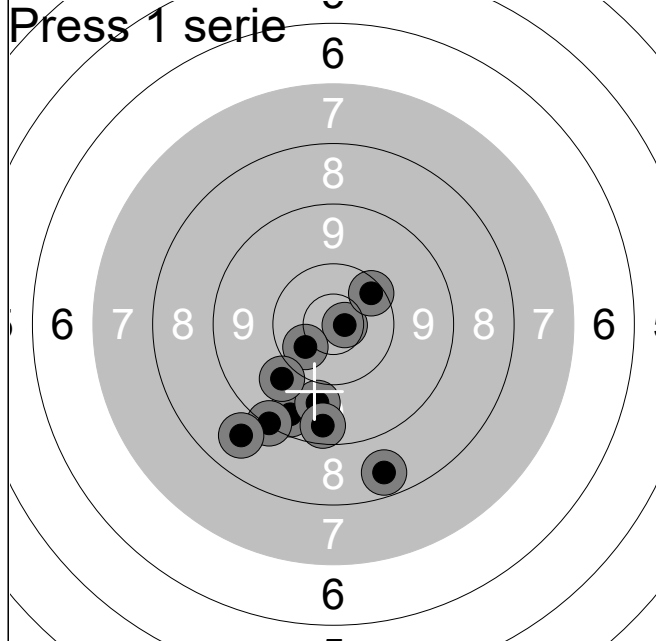

17.0s	10.8x	→
45.6s	9.5	↓
1:45m	10.4x	↙
2:40m	9.2	↓
3:15m	8.7	↙
1:09m	9.8	↓
1:30m	8.5	↓
1:55m	10.3	↗
2:26m	9.5	↓
2:54m	9.9	↙

Serie 91 (2x)

Total 91 (2x)

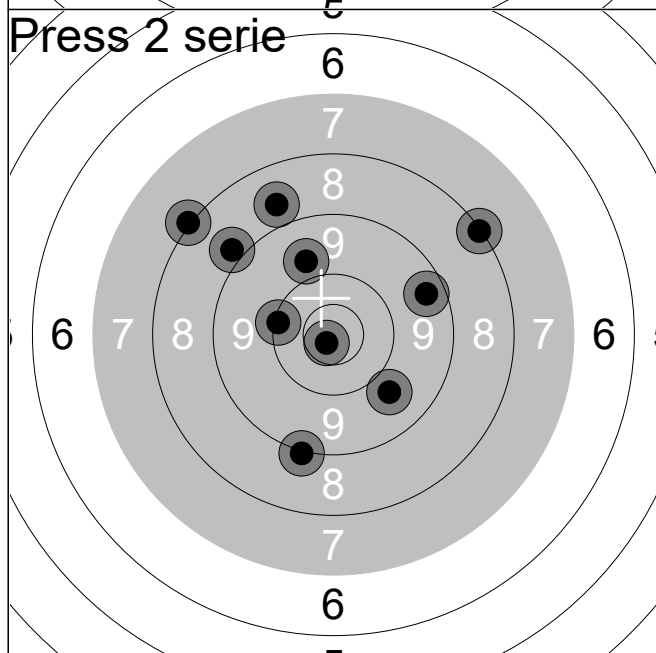

21.5s	8.2	↗
44.9s	9.5	↗
1:39m	9.8	↑
2:05m	8.8	↑
3:05m	9.1	↓
14.4s	9.8	↓
37.2s	10.8x	↓
56.9s	10.2	←
1:20m	8.1	↗
1:49m	8.9	↗

Serie 88 (1x)

Total 179 (3x)

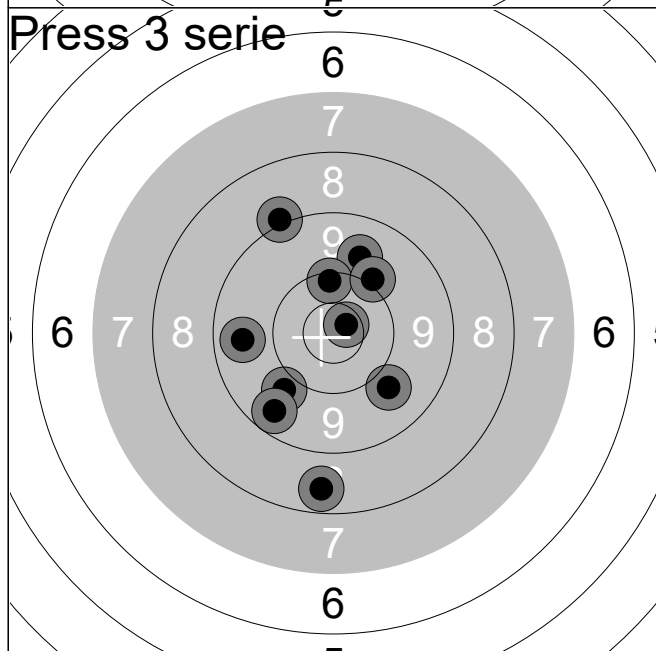

16.7s	9.8	↑
1:11m	9.1	↑
1:41m	9.6	←
3:05m	9.9	↓
4:10m	9.9	↘
47.0s	10.2	↑
1:06m	10.0	↗
1:26m	10.7x	↗
1:45m	8.5	↓
2:04m	9.5	↙

Serie 92 (1x)

Total 271 (4x)

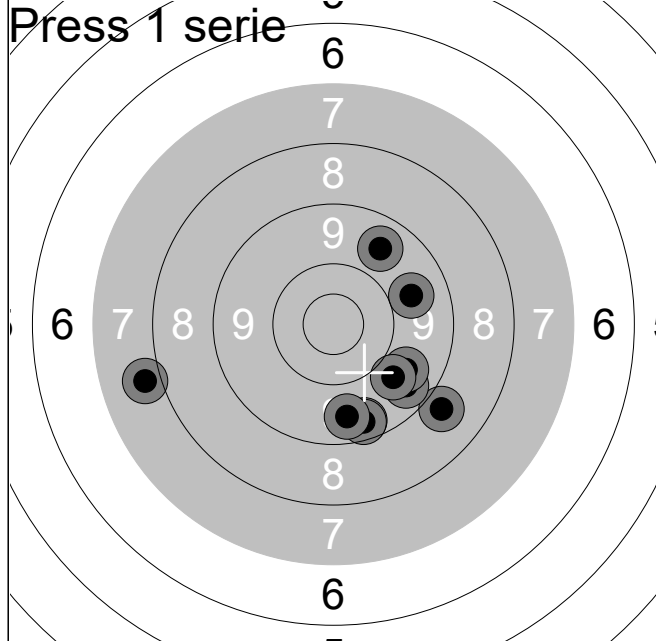

9.17s	9.8	→
40.3s	8.9	↘
1:22m	9.6	↘
2:10m	9.5	↘
2:55m	9.7	↗
9.27s	9.7	↘
45.2s	9.4	↘
1:31m	7.9	←
2:09m	9.8	↘
2:53m	9.6	↓
Serie		87 (0x)
Total		87 (0x)

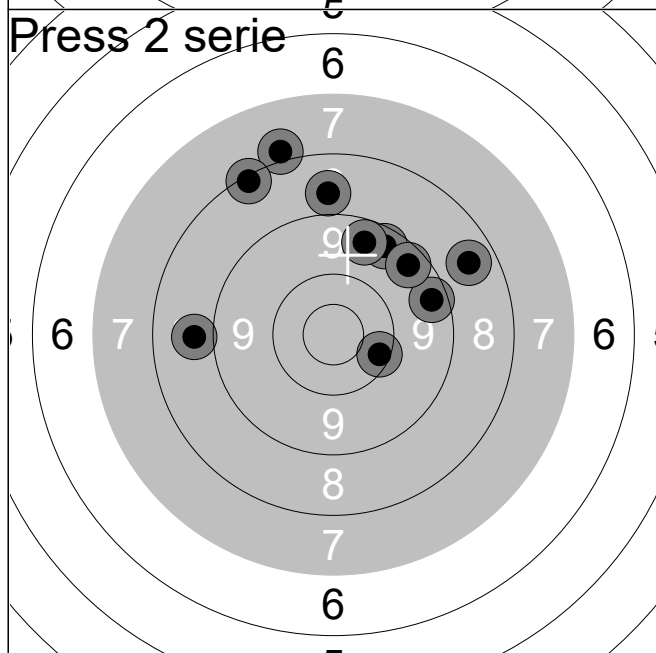

10.4s	9.4	→
41.6s	9.4	↗
1:19m	9.5	↗
2:11m	8.8	←
3:03m	8.6	→
8.06s	10.2	→
37.3s	8.0	↑
1:13m	8.8	↑
1:53m	9.4	↗
2:41m	8.2	↗
Serie		86 (0x)
Total		173 (0x)

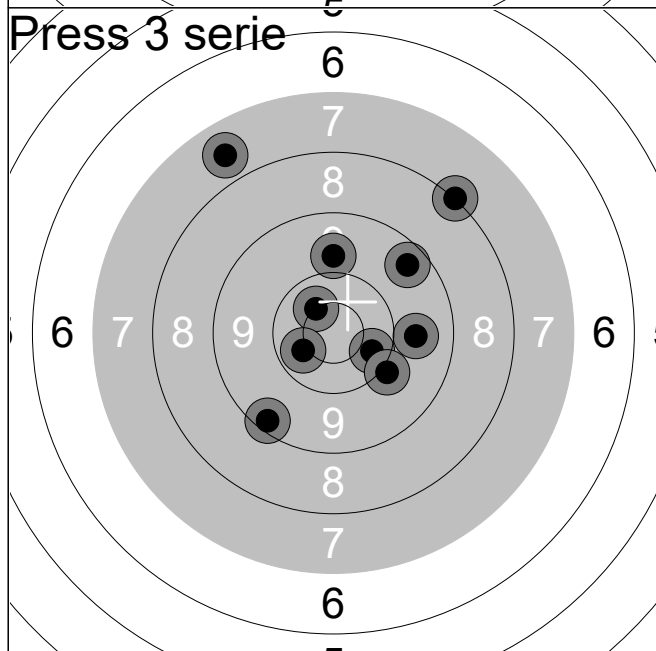

15.2s	9.5	↗
57.0s	7.7	↗
1:29m	10.4	↘
2:07m	10.5x	↗
2:45m	8.1	↗
12.8s	9.8	→
48.4s	9.9	↑
1:30m	10.0	↘
2:14m	10.5x	←
2:57m	9.3	↘
Serie		91 (2x)
Total		264 (2x)